

# Axial piston fixed pump A4FO

**RE 91455**

Edition: 03.2015

Replaces: 04.2000

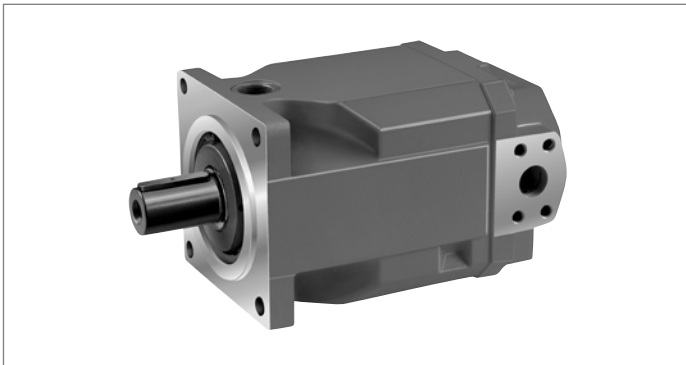

- ▶ Sizes 22 and 28
  - Nominal pressure 400 bar
  - Maximum pressure 450 bar
- ▶ Sizes 71 to 500
  - Nominal pressure 350 bar
  - Maximum pressure 400 bar

**Features**

- ▶ Fixed pump in axial piston swashplate design for hydrostatic drives in an open circuit
- ▶ For use in mobile and stationary applications
- ▶ Flow is proportional to the drive speed and displacement.
- ▶ High power density
- ▶ High total efficiency
- ▶ Optimized dimensions for special installation situations
- ▶ Excellent suction characteristics
- ▶ Low noise level
- ▶ Long service life
- ▶ Economical design
- ▶ Through drive for combining additional pumps

**Contents**

Type code	2
Hydraulic fluids	4
Shaft seal	6
Flow direction	6
Working pressure range	7
Technical data	8
Dimensions sizes 22, 28	12
Dimensions size 71	14
Dimensions size 125	16
Dimensions size 180	18
Dimensions size 250	20
Dimensions size 500	22
Through drives dimensions	24
Overview of attachment options	25
Installation instructions	26
Project planning notes	28
Safety instructions	28

## Type code

01	02	03	04	05	06	07	08	09	10	11
	<b>A4F</b>	<b>O</b>	/			-				

Hydraulic fluid		022	028	071	125	180	250	500	
01	Mineral oil, HFD hydraulic fluid (no code)	●	●	●	●	●	●	●	
	HFA, HFB, HFC hydraulic fluid	-	-	●	●	●	●	●	E-
	High-speed version	-	-	-	-	-	●	●	H-

Axial piston unit		
02	Swashplate design, fixed displacement	<b>A4F</b>

Operating mode		
03	Pump, open circuit	<b>O</b>

Size (NG)		022	028	071	125	180	250	500
04	Geometric displacement, see „Technical data“ on page 8							

Series		022, 028	071	125 to 500	
05	Series 1, index 0	-	●	-	<b>10</b>
	Series 3, index 0	-	-	●	<b>30</b>
	Series 3, index 2	●	-	-	<b>32</b>

Direction of rotation			
06	Viewed on drive shaft	clockwise	<b>R</b>
		counter-clockwise	<b>L</b>

Sealing material		022, 028	071 to 500	
07	NBR (nitrile rubber), shaft seal in FKM (fluoroelastomer)	●	-	<b>N</b>
		-	●	<b>P</b>
	FKM (fluoroelastomer)	-	●	<b>V</b>

Drive shaft (permissible input torque, see page 10)		022	028	071	125	180	250	500	
08	Splined shaft ANSI B92.1a	●	●	-	-	-	-	-	<b>S</b>
	Splined shaft DIN 5480	-	-	●	●	●	●	●	<b>Z</b>
	Parallel keyed shaft DIN 6885	-	-	●	●	●	●	●	<b>P</b>

Mounting flange		022	028	071	125	180	250	500	
09	SAE J744, 2-hole	●	●	-	-	-	-	-	<b>C</b>
	ISO 3019, 4-hole	-	-	●	●	●	●	-	<b>B</b>
	ISO 3019, 8-hole	-	-	-	-	-	-	●	<b>H</b>

Working port <sup>1)</sup>		022, 028	071 to 500	
10	SAE pressure and suction port, at side, opposite	●	-	<b>12</b>
	SAE pressure and suction port, at side, offset by 90° 2nd pressure port B1 opposite B (plugged with flange plate on delivery)	-	●	<b>25</b>

● = Available    - = Not available

1) Fastening thread, metric

01	02	03	04	05	06	07	08	09	10	11
	<b>A4F</b>	<b>O</b>		/			-			

**Through drive** (for attachment options, see page 25)

		022	028	071	125	180	250	500		
11	Without through drive	●	●	●	●	●	●	●	<b>N00</b>	
	With through drive for mounting an axial piston unit or gear pump	●	●	●	-	-	-	●	<b>K...</b>	
	Universal through drive (can be modified)	-	-	-	●	●	●	-	<b>U...</b>	
	Flange SAE J744	Hub for splined shaft SAE J744								
	82-2 (A)	5/8 in (16-4)	●	●	●	●	●	●	●	<b>...01</b>
	101-2 (B)	7/8 in (22-4)	●	●	-	-	-	-	-	<b>...02</b>
	101-2 (B)	7/8 in (22-4)	-	-	●	●	●	●	○	<b>...68</b>
	Flange ISO 3019-2 (metric)	Hub for splined shaft SAE J744								
	80, 2-hole	3/4 in (19-4)	-	-	●	●	●	●	○	<b>...B2</b>
	100, 2-hole	7/8 in (22-4)	-	-	●	●	●	●	○	<b>...B3</b>
	100, 2-hole	1 in (25-4)	-	-	●	●	●	●	○	<b>...B4</b>
	125, 2-hole	1 1/4 in (32-4)	-	-	●	●	●	●	○	<b>...B5</b>
	125, 2-hole	1 1/2 in (38-4)	-	-	-	●	●	●	○	<b>...B6</b>
	180, 4-hole	1 3/4 in (44-4)	-	-	-	-	●	●	●	<b>...B7</b>
	Flange ISO 3019-2 (metric)	Hub for splined shaft DIN 5480								
	125, 4-hole	W32×2×14×9g	-	-	●	●	●	●	○	<b>...31</b>
	140, 4-hole	W40×2×18×9g	-	-	●	●	●	●	○	<b>...33</b>
	160, 4-hole	W50×2×24×9g	-	-	-	●	●	●	●	<b>...34</b>
	224, 4-hole	W60×2×28×9g	-	-	-	-	-	●	●	<b>...35</b>
	315, 8-hole	W80×3×25×9g	-	-	-	-	-	-	●	<b>...43</b>
With through-drive shaft, without hub, without intermediate flange, closed with cover		-	-	●	●	●	●	●	<b>...99</b>	

● = Available    ○ = On request    - = Not available

**Notes**

- ▶ Note the project planning notes on page 28.
- ▶ Preservation:
  - Up to 12 months as standard
  - Up to 24 months long-term (state in plain text when ordering)

## Hydraulic fluids

The A4FO fixed pump is designed for operation with HLP mineral oil according to DIN 51524.

Application instructions and requirements for hydraulic fluids should be taken from the following data sheets

before the start of project planning:

- ▶ 90220: Hydraulic fluids based on mineral oils and related hydrocarbons
  - ▶ 90221: Environmentally acceptable hydraulic fluids
  - ▶ 90222: Fire-resistant, water-free hydraulic fluids (HFDR/HFDU)
  - ▶ 90223: Fire-resistant, water-containing hydraulic fluids (HFC, HFB, HFAE, HFAS)
- Sizes 22 and 28 are not suitable for operation with HFA, HFB and HFC.

### Details regarding the choice of hydraulic fluid

The hydraulic fluid should be selected such that the operating viscosity in the operating temperature range is within the optimum range ( $\nu_{opt}$ , see selection diagram).

### Note

At no point of the component may the temperature be higher than 115 °C (sizes 22 and 28) and 90 °C (sizes 71 to 500).

The temperature difference specified in the table is to be taken into account when determining the viscosity in the bearing.

If the above conditions cannot be maintained due to extreme operating parameters, please contact the responsible member of staff at Bosch Rexroth.

## Viscosity and temperature of hydraulic fluids

### ▼ Sizes 22 and 28

	Viscosity	Temperature	Comment
Cold start	$\nu_{max} \leq 1600 \text{ mm}^2/\text{s}$	$\theta_{St} \geq -40 \text{ °C}$	$t \leq 3 \text{ min}$ , $n \leq 1000 \text{ rpm}$ , without load $p \leq 50 \text{ bar}$
	Permissible temperature difference	$\Delta T \leq 25 \text{ K}$	between axial piston unit and hydraulic fluid in the system
Warm-up phase	$\nu_{max} < 1600 \text{ to } 400 \text{ mm}^2/\text{s}$	$\theta = -40 \text{ °C to } -25 \text{ °C}$	at $p \leq 0,7 \times p_{nom}$ , $n \leq 0,5 \times n_{nom}$ and $t \leq 15 \text{ min}$
Continuous operation	$\nu = 400 \text{ to } 10 \text{ mm}^2/\text{s}$	$\theta = -25 \text{ °C to } +110 \text{ °C}$	measured at port <b>T<sub>1</sub></b> or <b>T<sub>2</sub></b> Note the permissible temperature range of the shaft seal ( $\Delta T = \text{approx. } 5 \text{ K}$ between the bearing/shaft seal and port <b>T<sub>1</sub>/T<sub>2</sub></b> )
	$\nu_{opt} = 36 \text{ to } 16 \text{ mm}^2/\text{s}$		Range of optimum operating viscosity and efficiency
Short-term operation	$\nu_{min} \geq 7 \text{ mm}^2/\text{s}$		$t < 3 \text{ min}$ , $p < 0,3 \times p_{nom}$

### ▼ Sizes 71 to 500

	Viscosity	Temperature	Comment
Cold start	$\nu_{max} \leq 1000 \text{ mm}^2/\text{s}$	$\theta_{St} \geq -40 \text{ °C}$	$t \leq 3 \text{ min}$ , $n \leq 1000 \text{ rpm}$ , without load $p \leq 50 \text{ bar}$
	Permissible temperature difference	$\Delta T \leq 25 \text{ K}$	between axial piston unit and hydraulic fluid in the system
Warm-up phase	$\nu_{max} < 1000 \text{ to } 100 \text{ mm}^2/\text{s}$	$\theta = -40 \text{ °C to } -25 \text{ °C}$	at $p \leq 0,7 \times p_{nom}$ , $n \leq 0,5 \times n_{nom}$ and $t \leq 15 \text{ min}$
Continuous operation	$\nu = 100 \text{ to } 16 \text{ mm}^2/\text{s}$	$\theta = -25 \text{ °C to } +90 \text{ °C}$	measured at port <b>T</b> Note the permissible temperature range of the shaft seal
	$\nu_{opt} = 36 \text{ to } 16 \text{ mm}^2/\text{s}$		Range of optimum operating viscosity and efficiency
Short-term operation	$\nu_{min} \geq 10 \text{ mm}^2/\text{s}$		$t < 3 \text{ min}$ , $p < 0,3 \times p_{nom}$

▼ Selection diagram

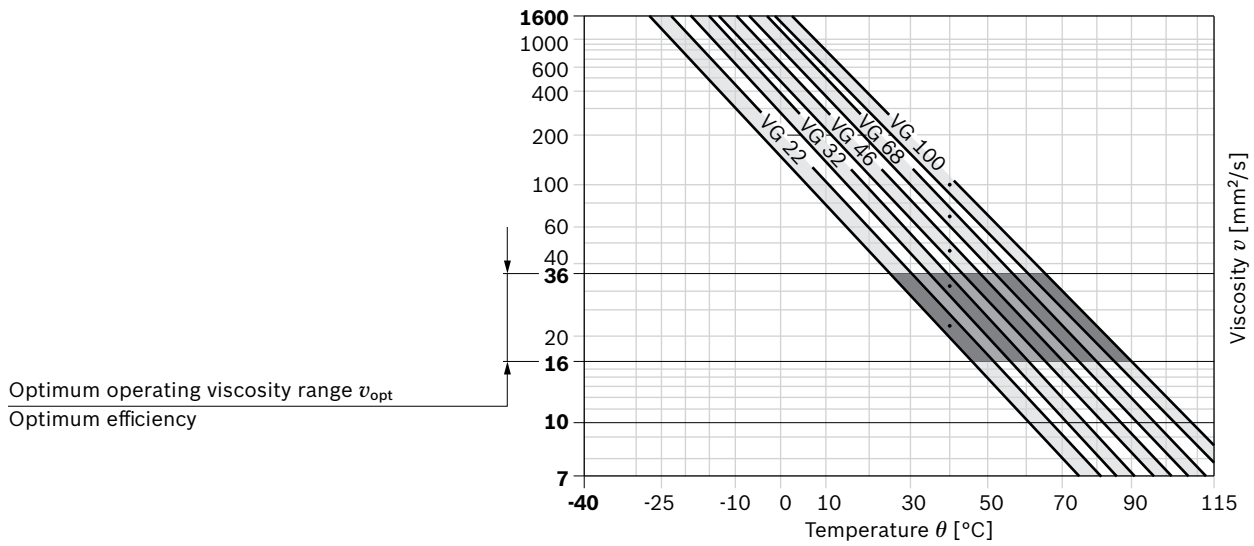

**Filtration of the hydraulic fluid**

Finer filtration improves the cleanliness level of the hydraulic fluid, which in turn increases the service life of the axial piston unit.

A cleanliness level of at least 20/18/15 is to be maintained according to ISO 4406.

At very high hydraulic fluid temperatures (90 °C to maximum 110 °C, measured at port **T**, not permitted for sizes 71 to 500), a cleanliness level of at least 19/17/14 in accordance with ISO 4406 is necessary.

## Shaft seal

### Permissible pressure loading

The service life of the shaft seal is influenced by the speed of the axial piston unit and the leakage pressure in the housing (case pressure). Momentary ( $t < 0,1$  s) pressure peaks of up to 10 bar are allowed. The service life of the shaft seal decreases with increasing frequency of pressure peaks and increasing mean differential pressure. The case pressure must be equal to or higher than the ambient pressure.

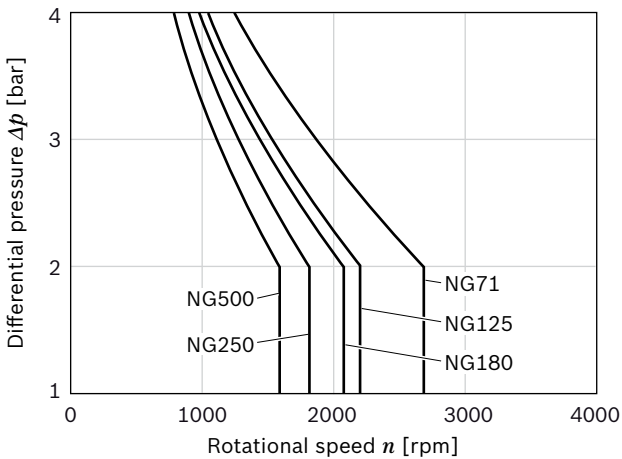

The FKM shaft seal may be used for leakage temperatures from  $-25$  °C to  $+115$  °C.

**Sizes 22 and 28:** For application cases below  $-25$  °C, an NBR shaft seal is required (permissible temperature range:  $-40$  °C to  $+90$  °C).

## Flow direction

### Direction of rotation, viewed on drive shaft, sizes 22 and 28

clockwise	counter-clockwise
<b>S to B</b>	<b>S to A</b>

### ▼ Schematic, sizes 22 and 28

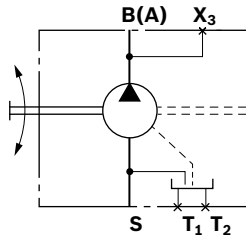

#### Ports

- A, B** Working port
- S** Suction port
- T<sub>1</sub>, T<sub>2</sub>** Drain port
- X<sub>3</sub>** Measuring pressure B (A)

### Direction of rotation, viewed on drive shaft, sizes 71 to 500

clockwise	counter-clockwise
<b>S to B</b>	<b>S to B</b>

### ▼ Schematic, sizes 71 to 500

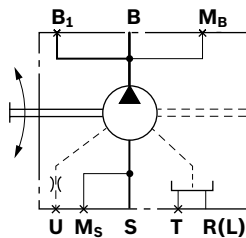

#### Ports

- B, B<sub>1</sub>** Working port
- S** Suction port
- T** Drain port
- R (L)** Filling / air bleeding
- M<sub>B</sub>** Measuring port working pressure
- M<sub>S</sub>** Measuring port suction pressure
- U** Flushing port

### Bearing flushing (sizes 71 to 500)

Please refer to the data sheet 92050 (A4VSO) for operating conditions, flushing quantities and notes on bearing flushing.

## Working pressure range

Pressure at working ports A or B and B <sub>1</sub>	Sizes 22 and 28	Sizes 71 to 500	Definition
Nominal pressure $p_{nom}$	400 bar absolute	350 bar absolute	The nominal pressure corresponds to the maximum design pressure.
Maximum pressure $p_{max}$	450 bar absolute	400 bar absolute	The maximum pressure corresponds the maximum working pressure within the single operating period. The sum of the single operating periods must not exceed the total operating period.
Single operating period	1 s	1 s	
Total operating period	300 h	300 h	
Minimum pressure (high-pressure side)	25 bar absolute	–	Minimum pressure on high-pressure side (A or B and B <sub>1</sub> ) required to prevent damage to the axial piston unit.
Rate of pressure change $R_{A\ max}$	16000 bar/s	16000 bar/s	Maximum permissible rate of pressure build-up and reduction during a pressure change over the entire pressure range.
Pressure at suction port S (inlet)			
Minimum pressure $p_{S\ min}$	0,8 bar absolute	0,8 bar absolute	Minimum pressure at suction port S (inlet) that is required in order to avoid damage to the axial piston unit. The minimum pressure depends on the speed of the axial piston unit.
Maximum pressure $p_{S\ max}$	2 bar absolute	30 bar absolute	

### ▼ Rate of pressure change $R_{A\ max}$

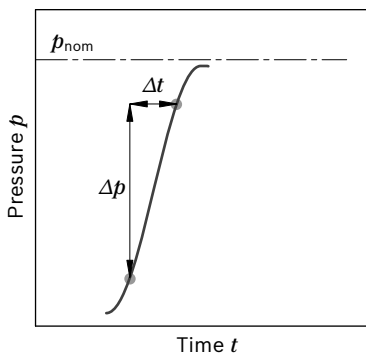

### ▼ Pressure definition

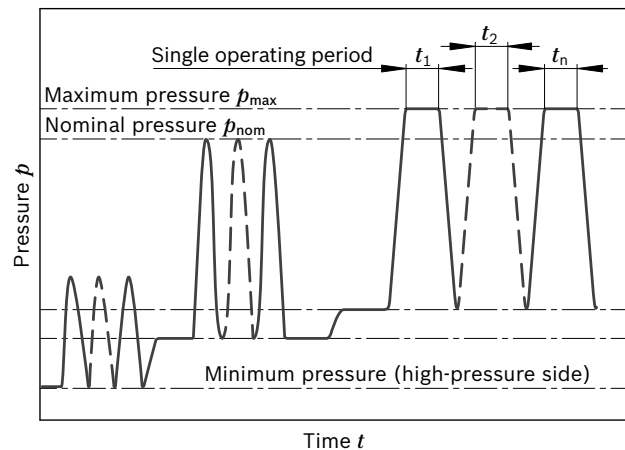

$$\text{Total operating period} = t_1 + t_2 + \dots + t_n$$

### Note

Working pressure range valid when using hydraulic fluids based on mineral oils. Values for other hydraulic fluids, please contact us.

## Technical data

Size		NG	22	28	71	125	180	250/H <sup>1)</sup>	500/H <sup>1)</sup>	
Displacement, geometric, per revolution		$V_g$	cm <sup>3</sup>	22	28	71	125	180	250	500
Maximum rotational speed <sup>2)</sup>		$n_{nom}$	rpm	3600	3000	2200	1800	1800	1500 / 1900	1320 / 1500
Maximum rotational speed <sup>3)</sup>		$n_{max}$	rpm	4500	3750	2700	2200	2100	1800 / 2100	1600 / 1800
Flow	at $V_g$ and $n_{nom}$	$q_v$	l/min	79	84	156	225	324	375 / 475	660 / 750
Power	at $V_g$ , $n_{nom}$ and $\Delta p = 400$ bar	$P$	kW	53	56	91 <sup>4)</sup>	131 <sup>4)</sup>	189 <sup>4)</sup>	219 / 277 <sup>4)</sup>	385 / 438 <sup>4)</sup>
Torque	at $V_g$ and $\Delta p = 400$ bar	$T$	Nm	140	178	396 <sup>4)</sup>	696 <sup>4)</sup>	1003 <sup>4)</sup>	1393 <sup>4)</sup>	2785 <sup>4)</sup>
Rotary stiffness drive shaft	Shaft end <b>S</b>	$c$	kNm/rad	29,9	29,9	–	–	–	–	–
	Shaft end <b>P</b>	$c$	kNm/rad	–	–	146	260	328	527	1145
	Shaft end <b>Z</b>	$c$	kNm/rad	–	–	146	263	332	543	1136
Moment of inertia for rotary group		$J_{GR}$	kgm <sup>2</sup>	0,0017	0,0017	0,0121	0,0300	0,055	0,0959	0,3325
Maximum angular acceleration		$a$	rad/s <sup>2</sup>	38000	38000	20000	13000	10000	8000	4800
Case volume		$V$	l	0,3	0,3	2,0	3,0	4,0	7,0	11,0
Weight (approx.)		$m$	kg	13,5	13,5	34	61	76	120	220

### ▼ Maximum permissible speed (speed limit)

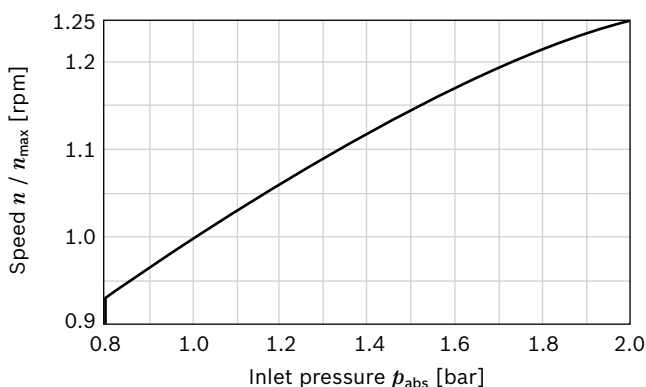

#### Notes

- ▶ Theoretical values, without efficiency and tolerances; values rounded
- ▶ Operation above the maximum values or below the minimum values may result in a loss of function, a reduced service life or the destruction of the axial piston unit. Bosch Rexroth recommend testing the loads by means of experiment or calculation / simulation and comparison with the permissible values.

### Determining operating characteristics

Flow	$q_v = \frac{V_g \times n \times \eta_v}{1000}$	[l/min]
Torque	$T = \frac{V_g \times \Delta p}{20 \times \pi \times \eta_{mh}}$	[Nm]
Power	$P = \frac{2 \pi \times T \times n}{60000} = \frac{q_v \times \Delta p}{600 \times \eta_t}$	[kW]
Key		
$V_g$	=	Displacement per revolution [cm <sup>3</sup> ]
$\Delta p$	=	Differential pressure [bar]
$n$	=	Rotational speed [rpm]
$\eta_v$	=	Volumetric efficiency
$\eta_{mh}$	=	Mechanical-hydraulic efficiency
$\eta_t$	=	Total efficiency ( $\eta_t = \eta_v \times \eta_{mh}$ )

1) H = High-speed version

2) The values are valid:

- At absolute pressure  $p_{abs} = 1$  bar at suction port **S**
- For the optimal viscosity range of  $\nu_{opt} = 36$  to  $16$  mm<sup>2</sup>/s
- For hydraulic fluid based on mineral oils.

3) Maximum speed (speed limit) with increased inlet pressure  $p_{abs}$  at suction port **S**, see diagram.

4) At  $\Delta p = 350$  bar



**Permissible radial and axial forces of the drive shaft**

Size	NG		22	28
Drive shaft <b>S</b> according to ANSI B92.1a		in	7/8	7/8
Maximum radial force at distance a (from shaft collar)	$F_{q \max}$	N	2550	2150
	a	mm	16,5	16,5
Maximum axial force	$+ F_{ax \max}$	N	1557	1557
	$- F_{ax \max}$	N	417	417

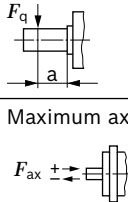

Size	NG		71	71	125	125	180	180	250	250	500	500
Drive shaft <b>Z</b> according to DIN 5480				W40		W50		W50		W60		W80
Drive shaft <b>P</b> according to DIN 6885		mm	Ø40		Ø50		Ø50		Ø60		Ø80	
Maximum radial force at distance a (from shaft collar)	$F_{q \max}$	N	1200	1200	1600	1600	2000	2000	2000	2000	2500	2500
	a	mm	35	22,5	41	27	41	27	52,5	35	65	45
Maximum axial force	$+ F_{ax \max}$	N	800	800	1000	1000	1400	1400	1800	1800	2000	2000
	$- F_{ax \max}$	N	800	800	1000	1000	1400	1400	1800	1800	2000	2000

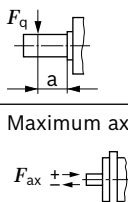
**Note**

Special requirements apply in the case of belt drive and cardan shaft. Please contact us.

**Permissible input and through-drive torques**

Size	NG		22	28
Torque at $V_g$ and $\Delta p = 400 \text{ bar}^1$	$T$	Nm	140	178
Input torque at drive shaft, maximum <sup>2)</sup>				
ANSI B92.1a	S	$T_{E \text{ max}}$	Nm	192
			7/8 in	7/8 in
Maximum through-drive torque	$T_{D \text{ max}}$	Nm	192	192

Size	NG		71	125	180	250	500
Torque at $V_g$ and $\Delta p = 350 \text{ bar}^1$	T	Nm	396	696	1003	1393	2785
Input torque at drive shaft, maximum <sup>2)</sup>							
DIN 5480	Z	$T_{E \text{ max}}$	Nm	790	1392	2004	2782
				W40	W50	W50	W60
DIN 6885	P	$T_{E \text{ max}}$	Nm	700	1392	1400	2300
				Ø40	Ø50	Ø50	Ø60
Maximum through-drive torque	$T_{D \text{ max}}$	Nm	395	696	1002	1391	2783

▼ **Torque distribution**

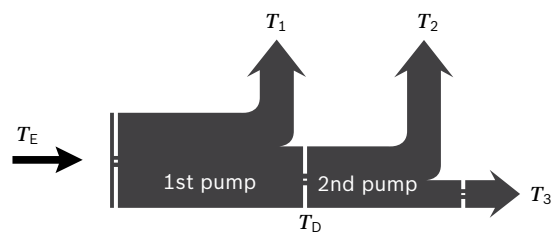

Torque at 1st pump	$T_1$
Torque at 2nd pump	$T_2$
Torque at 3rd pump	$T_3$
Input torque	$T_E = T_1 + T_2 + T_3$
	$T_E < T_{E \text{ max}}$
Through-drive torque	$T_D = T_2 + T_3$
	$T_D < T_{D \text{ max}}$

1) Efficiency not considered

2) For drive shafts free of radial force

**Flow and power**

▼ **Size 71**

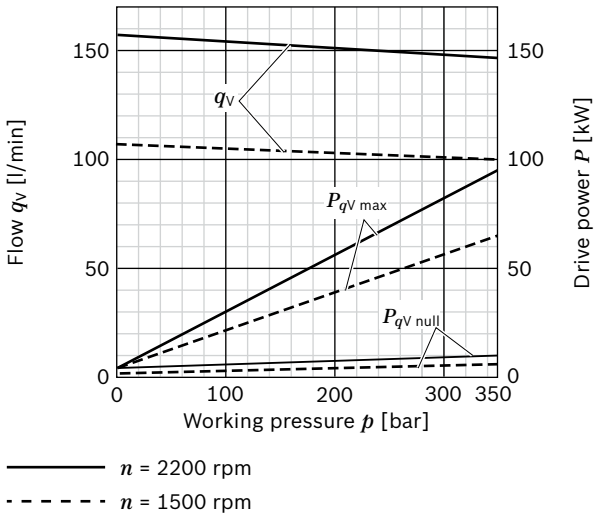

▼ **Size 250**

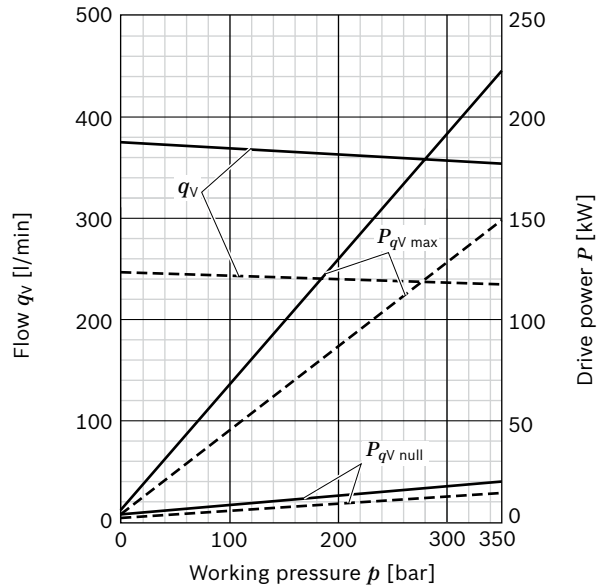

▼ **Size 125**

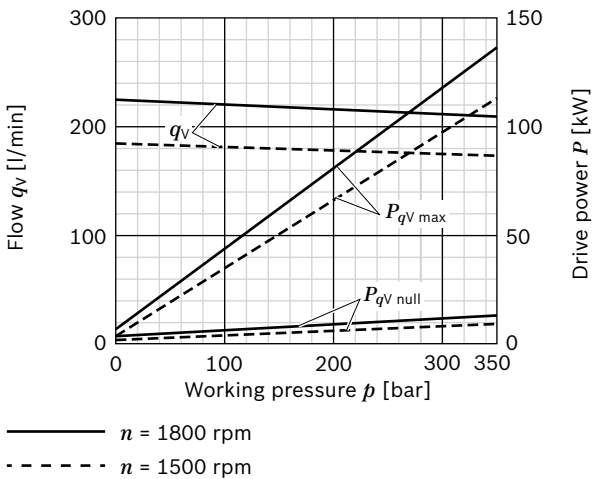

▼ **Size 500**

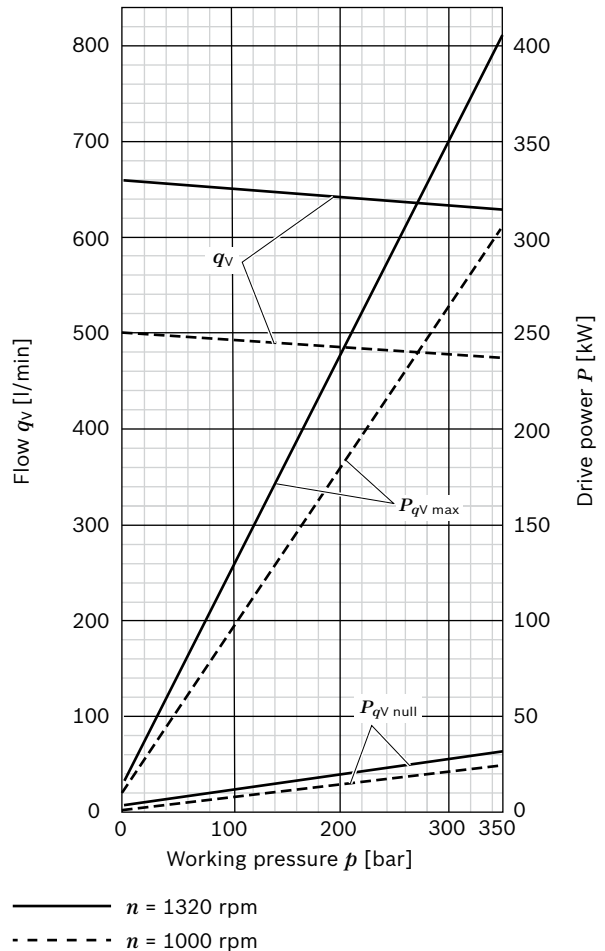

▼ **Size 180**

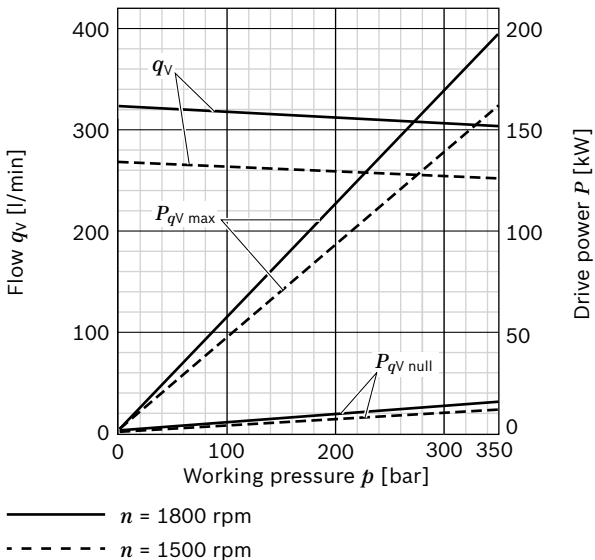



▼ **Splined shaft SAE J744**

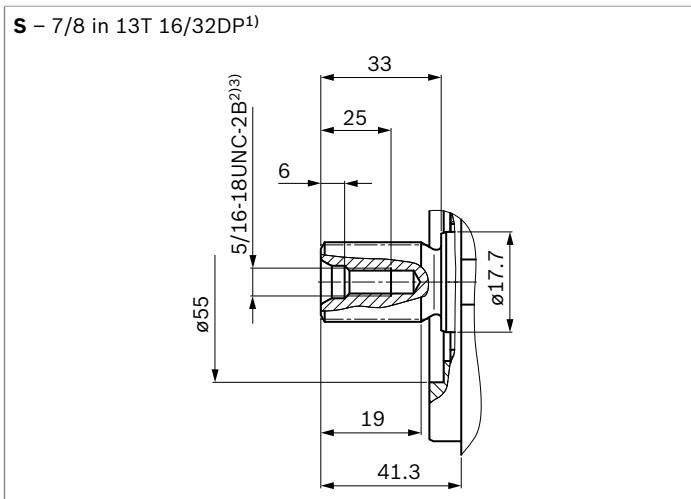

Ports		Standard	Size <sup>3)</sup>	$p_{\max \text{ abs}}$ [bar] <sup>4)</sup>	Status
<b>B (A)</b>	Working port (high-pressure series) fastening thread	SAE J518 <sup>5)</sup> DIN 13	3/4 in M10 × 1,5; 17 deep	450	O
<b>S</b>	Suction port (standard series) fastening thread	SAE J518 <sup>5)</sup> DIN 13	1 1/2 in M12 × 1,75; 18 deep	35	O
<b>T<sub>1</sub></b>	Drain port	DIN 3852 <sup>6)</sup>	M18 × 1,5; 12 deep	2	X
<b>T<sub>2</sub></b>	Drain port	DIN 3852 <sup>6)</sup>	M18 × 1,5; 12 deep	2	X
<b>X<sub>3</sub></b>	Measuring pressure B (A)	DIN 3852 <sup>6)</sup>	M14 × 1,5; 12 deep	450	X

1) Involute spline according to ANSI B92.1a, 30° pressure angle, flat root, side fit, tolerance class 5  
 2) Thread according to ASME B1.1  
 3) For notes on tightening torques, see instruction manual  
 4) Depending on the application, momentary pressure peaks can occur. Keep this in mind when selecting measuring devices and fittings.

5) Only dimensions according to SAE J518, metric fastening thread is a deviation from the standard  
 6) The spot face can be deeper than as specified in the standard  
 O = Must be connected (plugged on delivery)  
 X = Plugged (in normal operation)

### Dimensions size 71

#### Representation with clockwise and counter-clockwise direction of rotation

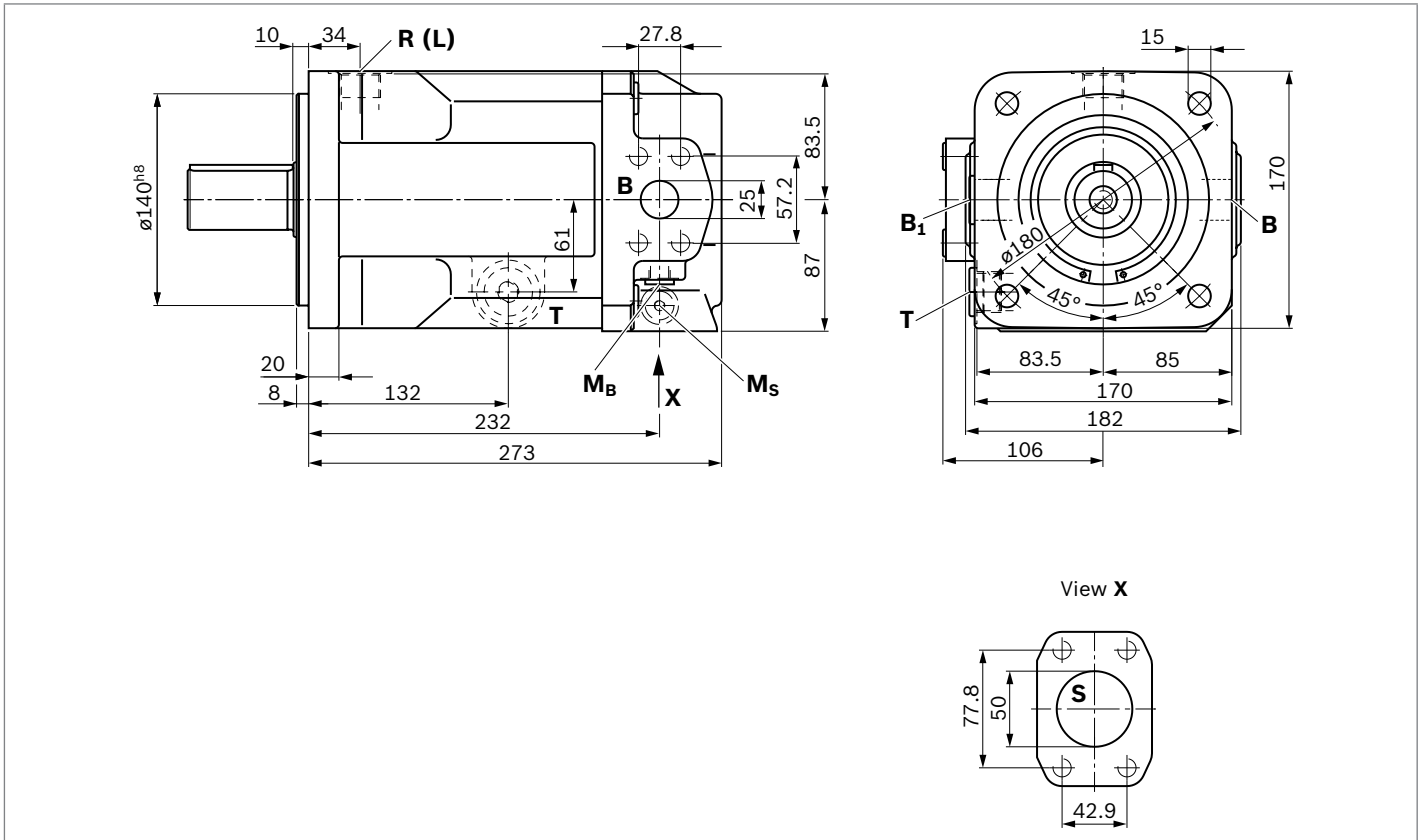

## ▼ Splined shaft DIN 5480

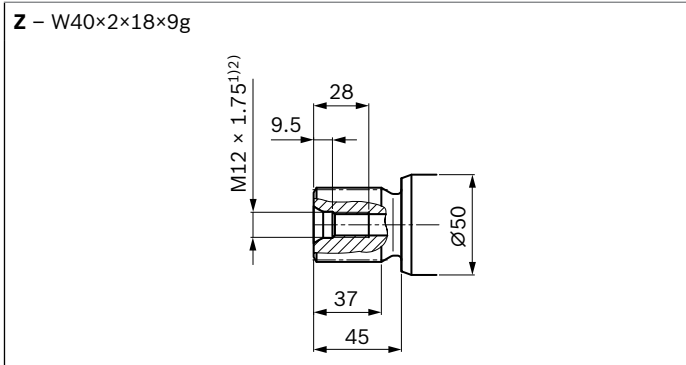

## ▼ Parallel keyed shaft DIN 6885

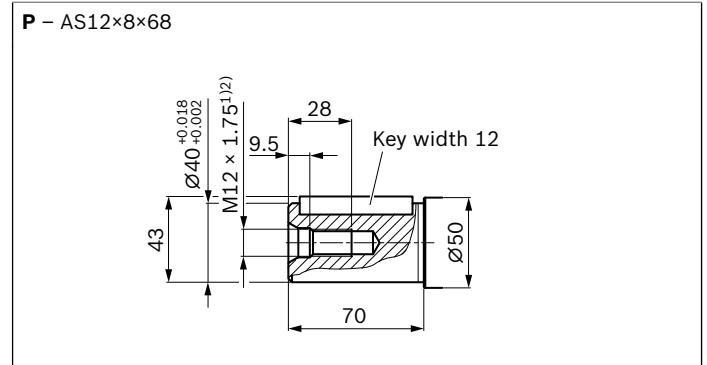

Ports		Standard	Size <sup>2)</sup>	$p_{\max \text{ abs}}$ [bar] <sup>3)</sup>	Status
<b>B</b>	Working port (high-pressure series) fastening thread	SAE J518 <sup>4)</sup> DIN 13	1 in M12 × 1,75; 17 deep	400	O
<b>B<sub>1</sub></b>	2nd working port (high-pressure series) fastening thread	SAE J518 <sup>4)</sup> DIN 13	1 in M12 × 1,75; 17 deep	400	X
<b>S</b>	Suction port (standard series) fastening thread	SAE J518 <sup>4)</sup> DIN 13	2 in M12 × 1,75; 20 deep	30	O
<b>T</b>	Drain port	DIN 3852 <sup>5)</sup>	M27 × 2; 16 deep	4	X
<b>R (L)</b>	Filling / air bleeding (drain port)	DIN 3852 <sup>5)</sup>	M27 × 2; 16 deep	4	O
<b>M<sub>B</sub></b>	Measuring pressure B	DIN 3852 <sup>5)</sup>	M14 × 1,5; 12 deep	400	X
<b>M<sub>S</sub></b>	Measuring pressure S	DIN 3852 <sup>5)</sup>	M14 × 1,5; 12 deep	30	X

1) Center bore according to DIN 332 (thread according to DIN 13)

2) For notes on tightening torques, see instruction manual

3) Depending on the application, momentary pressure peaks can occur.  
Keep this in mind when selecting measuring devices and fittings.

4) Only dimensions according to SAE J518, metric fastening thread is a deviation from the standard.

5) The spot face can be deeper than as specified in the appropriate standard.

O = Must be connected (plugged on delivery)

X = Plugged (in normal operation)

### Dimensions size 125

Representation with clockwise and counter-clockwise direction of rotation

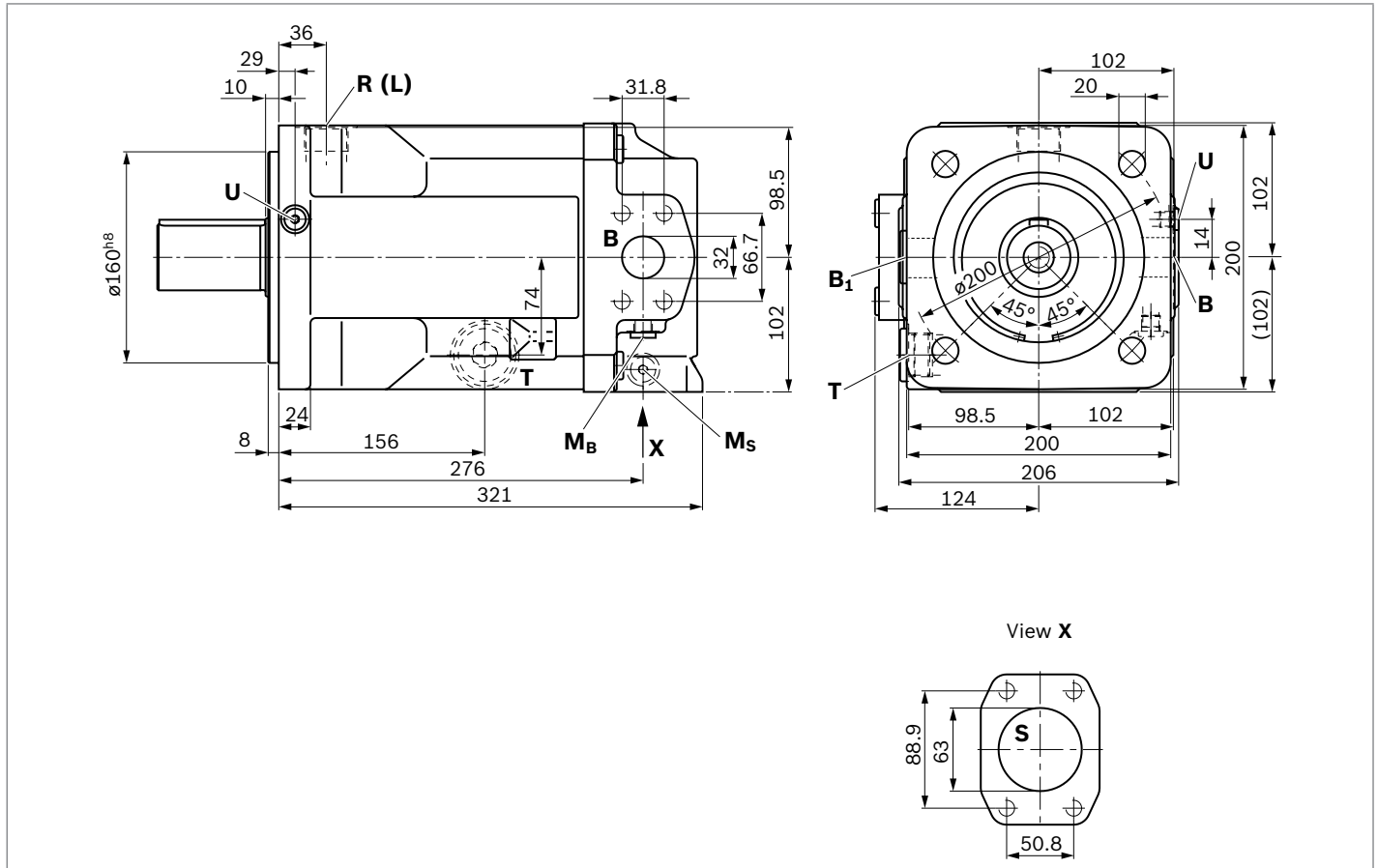



## ▼ Splined shaft DIN 5480

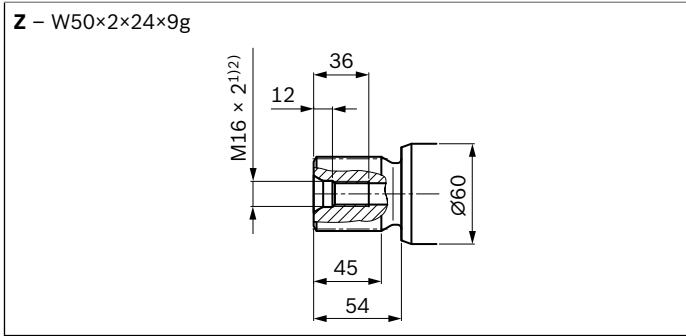

## ▼ Parallel keyed shaft DIN 6885

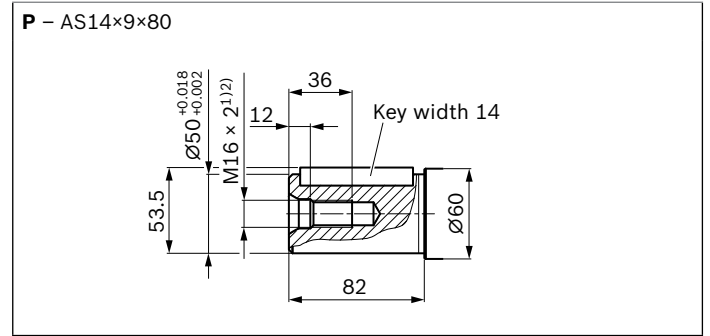

Ports		Standard	Size <sup>2)</sup>	$p_{\max \text{ abs}}$ [bar] <sup>3)</sup>	Status
<b>B</b>	Working port (high-pressure series) fastening thread	SAE J518 <sup>4)</sup> DIN 13	1 1/4 in M14 × 2; 19 deep	400	O
<b>B<sub>1</sub></b>	2nd working port (high-pressure series) fastening thread	SAE J518 <sup>4)</sup> DIN 13	1 1/4 in M14 × 2; 19 deep	400	X
<b>S</b>	Suction port (standard series) fastening thread	SAE J518 <sup>4)</sup> DIN 13	2 1/2 in M12 × 1,75; 17 deep	30	O
<b>T</b>	Drain port	DIN 3852 <sup>5)</sup>	M33 × 2; 18 deep	4	X
<b>R (L)</b>	Filling / air bleeding (drain port)	DIN 3852 <sup>5)</sup>	M33 × 2; 18 deep	4	O
<b>M<sub>B</sub></b>	Measuring pressure B	DIN 3852 <sup>5)</sup>	M14 × 1,5; 12 deep	400	X
<b>M<sub>S</sub></b>	Measuring pressure S	DIN 3852 <sup>5)</sup>	M14 × 1,5; 12 deep	30	X
<b>U</b>	Bearing flushing	DIN 3852 <sup>5)</sup>	M14 × 1,5; 12 deep	10	X

- 1) Center bore according to DIN 332 (thread according to DIN 13)
- 2) For notes on tightening torques, see instruction manual
- 3) Depending on the application, momentary pressure peaks can occur. Keep this in mind when selecting measuring devices and fittings.

- 4) Only dimensions according to SAE J518, metric fastening thread is a deviation from the standard.
  - 5) The spot face can be deeper than as specified in the appropriate standard.
- O = Must be connected (plugged on delivery)  
X = Plugged (in normal operation)

**Dimensions size 180**

**Representation with clockwise and counter-clockwise direction of rotation**

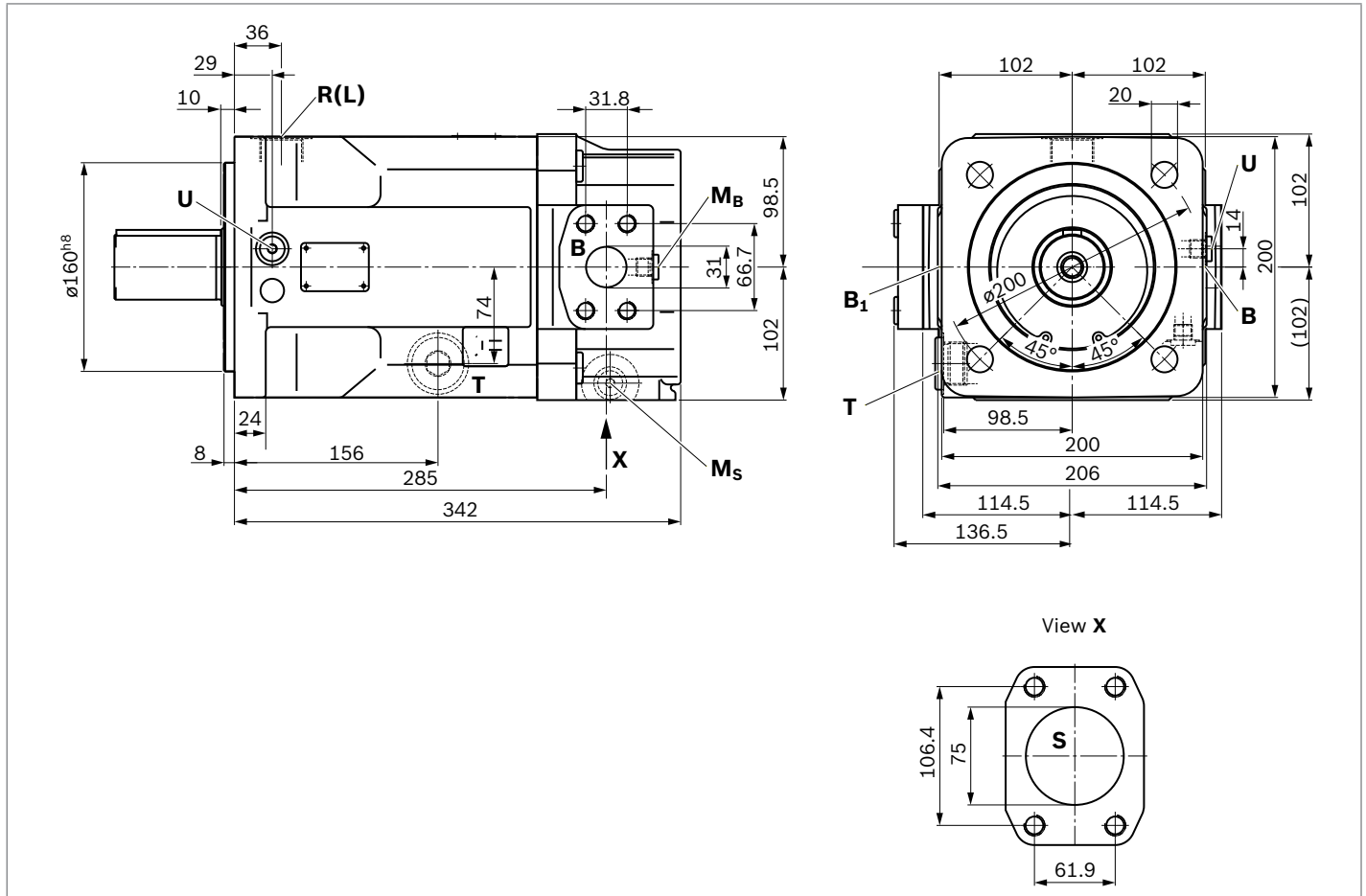

## ▼ Splined shaft DIN 5480

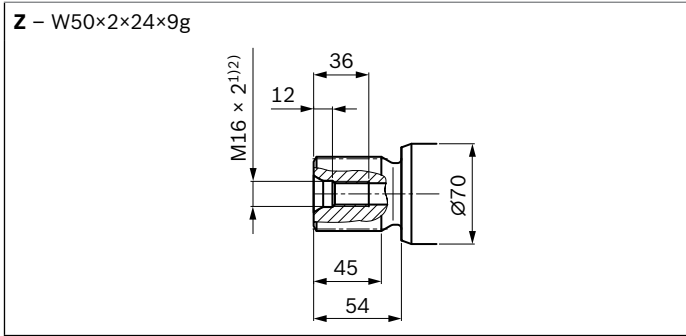

## ▼ Parallel keyed shaft DIN 6885

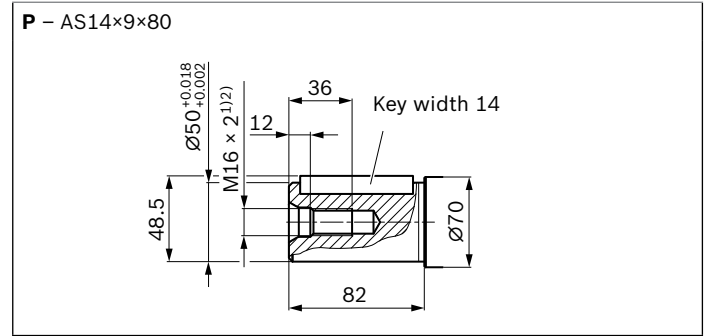

Ports		Standard	Size <sup>2)</sup>	$p_{\max \text{ abs}}$ [bar] <sup>3)</sup>	Status
<b>B</b>	Working port (high-pressure series) fastening thread	SAE J518 <sup>4)</sup> DIN 13	1 1/4 in M14 × 2; 19 deep	400	O
<b>B<sub>1</sub></b>	2nd working port (high-pressure series) fastening thread	SAE J518 <sup>4)</sup> DIN 13	1 1/4 in M14 × 2; 19 deep	400	X
<b>S</b>	Suction port (standard series) fastening thread	SAE J518 <sup>4)</sup> DIN 13	3 in M16 × 2; 24 deep	30	O
<b>T</b>	Drain port	DIN 3852 <sup>5)</sup>	M33 × 2; 18 deep	4	X
<b>R (L)</b>	Filling / air bleeding (drain port)	DIN 3852 <sup>5)</sup>	M33 × 2; 18 deep	4	O
<b>M<sub>B</sub></b>	Measuring pressure B	DIN 3852 <sup>5)</sup>	M14 × 1,5; 12 deep	400	X
<b>M<sub>S</sub></b>	Measuring pressure S	DIN 3852 <sup>5)</sup>	M14 × 1,5; 12 deep	30	X
<b>U</b>	Bearing flushing	DIN 3852 <sup>5)</sup>	M14 × 1,5; 12 deep	10	X

- 1) Center bore according to DIN 332 (thread according to DIN 13)
- 2) For notes on tightening torques, see instruction manual
- 3) Depending on the application, momentary pressure peaks can occur. Keep this in mind when selecting measuring devices and fittings.

- 4) Only dimensions according to SAE J518, metric fastening thread is a deviation from the standard.
  - 5) The spot face can be deeper than as specified in the appropriate standard.
- O = Must be connected (plugged on delivery)  
X = Plugged (in normal operation)

### Dimensions size 250

Representation with clockwise and counter-clockwise direction of rotation

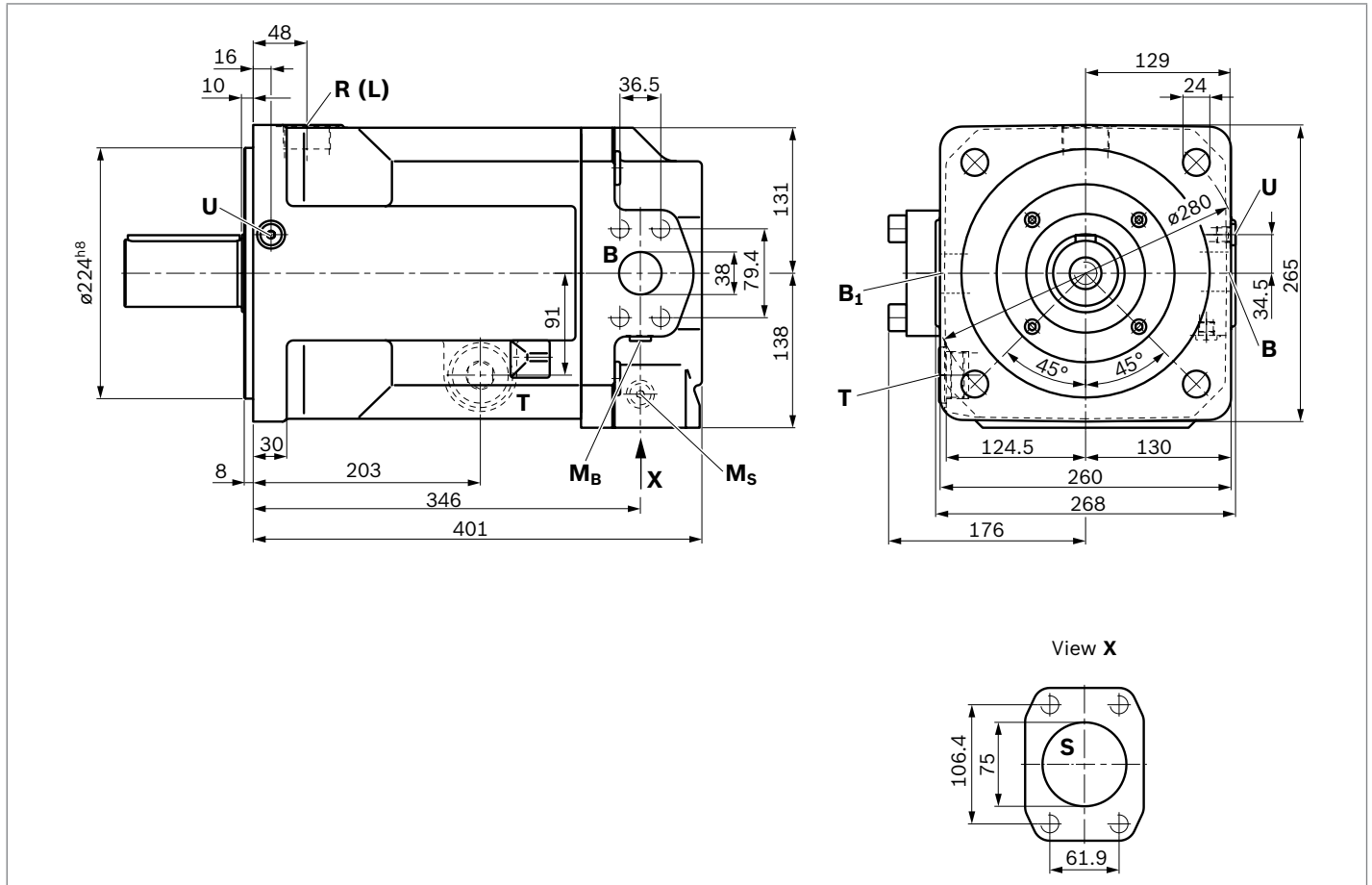

## ▼ Splined shaft DIN 5480

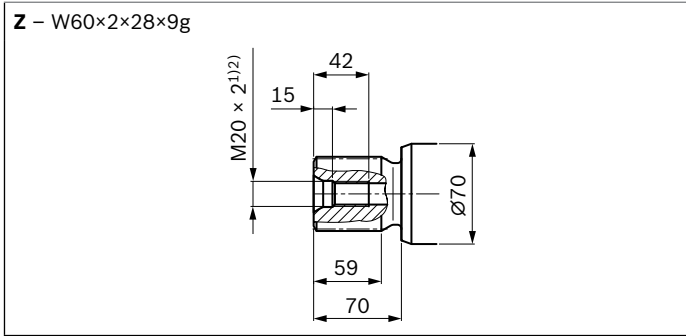

## ▼ Parallel keyed shaft DIN 6885

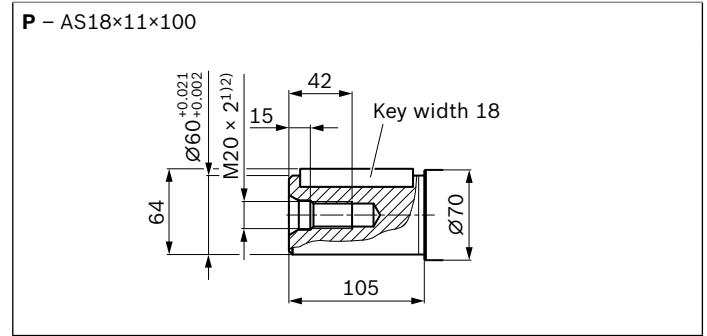

Ports	Standard	Size <sup>2)</sup>	$p_{\max \text{ abs}}$ [bar] <sup>3)</sup>	Status
<b>B</b>	Working port (high-pressure series) fastening thread	SAE J518 <sup>4)</sup> DIN 13	1 1/2 in M16 × 2; 24 deep	400 O
<b>B<sub>1</sub></b>	2nd working port (high-pressure series) fastening thread	SAE J518 <sup>4)</sup> DIN 13	1 1/2 in M16 × 2; 24 deep	400 X
<b>S</b>	Suction port (standard series) fastening thread	SAE J518 <sup>4)</sup> DIN 13	3 in M16 × 2; 24 deep	30 O
<b>T</b>	Drain port	DIN 3852 <sup>5)</sup>	M42 × 2; 20 deep	4 X
<b>R (L)</b>	Filling / air bleeding (drain port)	DIN 3852 <sup>5)</sup>	M42 × 2; 20 deep	4 O
<b>M<sub>B</sub></b>	Measuring pressure B	DIN 3852 <sup>5)</sup>	M14 × 1,5; 12 deep	400 X
<b>M<sub>S</sub></b>	Measuring pressure S	DIN 3852 <sup>5)</sup>	M14 × 1,5; 12 deep	30 X
<b>U</b>	Bearing flushing	DIN 3852 <sup>5)</sup>	M14 × 1,5; 12 deep	10 X

- 1) Center bore according to DIN 332 (thread according to DIN 13)
- 2) For notes on tightening torques, see instruction manual
- 3) Depending on the application, momentary pressure peaks can occur. Keep this in mind when selecting measuring devices and fittings.

- 4) Only dimensions according to SAE J518, metric fastening thread is a deviation from the standard.
  - 5) The spot face can be deeper than as specified in the appropriate standard.
- O = Must be connected (plugged on delivery)  
X = Plugged (in normal operation)

**Dimensions size 500**

**Representation with clockwise and counter-clockwise direction of rotation**

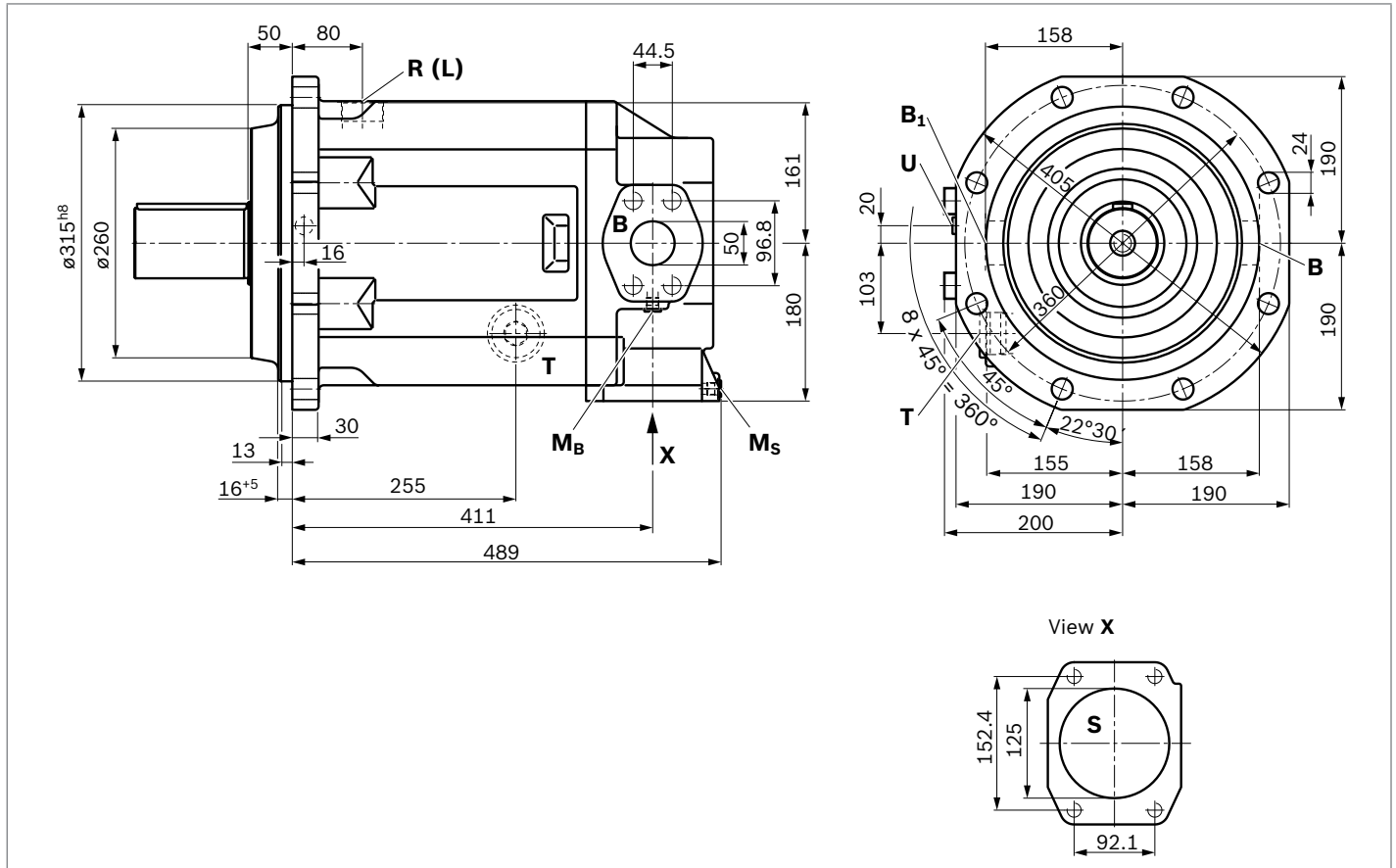

## ▼ Splined shaft DIN 5480

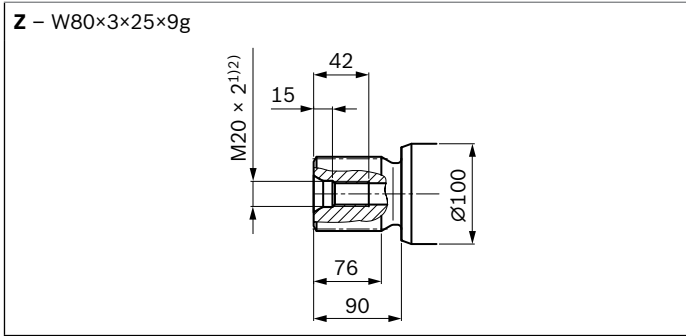

## ▼ Parallel keyed shaft DIN 6885

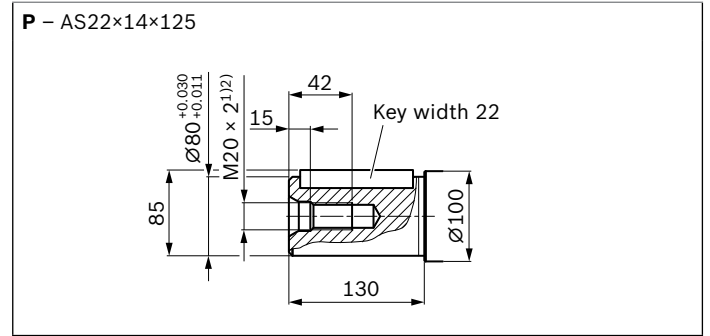

Ports	Standard	Size <sup>2)</sup>	$p_{\max \text{ abs}}$ [bar] <sup>3)</sup>	Status
<b>B</b>	Working port (high-pressure series) fastening thread	SAE J518 <sup>4)</sup> DIN 13	2 in M20 × 2,5; 24 deep	400 O
<b>B<sub>1</sub></b>	2nd working port (high-pressure series) fastening thread	SAE J518 <sup>4)</sup> DIN 13	2 in M20 × 2,5; 24 deep	400 X
<b>S</b>	Suction port (standard series) fastening thread	SAE J518 <sup>4)</sup> DIN 13	5 in M16 × 2; 23 deep	30 O
<b>T</b>	Drain port	DIN 3852 <sup>5)</sup>	M48 × 2; 22 deep	4 X
<b>R (L)</b>	Filling / air bleeding (drain port)	DIN 3852 <sup>5)</sup>	M48 × 2; 22 deep	4 O
<b>M<sub>B</sub></b>	Measuring pressure B	DIN 3852 <sup>5)</sup>	M18 × 1,5; 12 deep	400 X
<b>M<sub>S</sub></b>	Measuring pressure S	DIN 3852 <sup>5)</sup>	M18 × 1,5; 12 deep	30 X
<b>U</b>	Bearing flushing	DIN 3852 <sup>5)</sup>	M18 × 1,5; 12 deep	10 X

- 1) Center bore according to DIN 332 (thread according to DIN 13)
- 2) For notes on tightening torques, see instruction manual
- 3) Depending on the application, momentary pressure peaks can occur. Keep this in mind when selecting measuring devices and fittings.

- 4) Only dimensions according to SAE J518, metric fastening thread is a deviation from the standard.
  - 5) The spot face can be deeper than as specified in the appropriate standard.
- O = Must be connected (plugged on delivery)  
X = Plugged (in normal operation)

## Through drives dimensions

### Sizes 22 and 28

▼ **K01: Flange 82-2 (A), hub for splined shaft 5/8 in (16-4)**

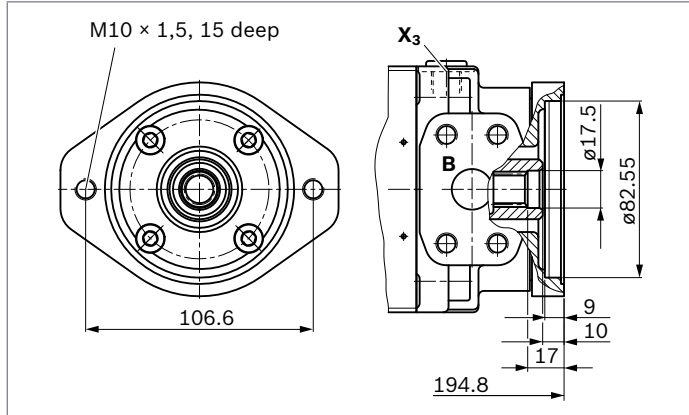

### Sizes 71 to 500

▼ For through drives see data sheet 92050 (A4VSO)

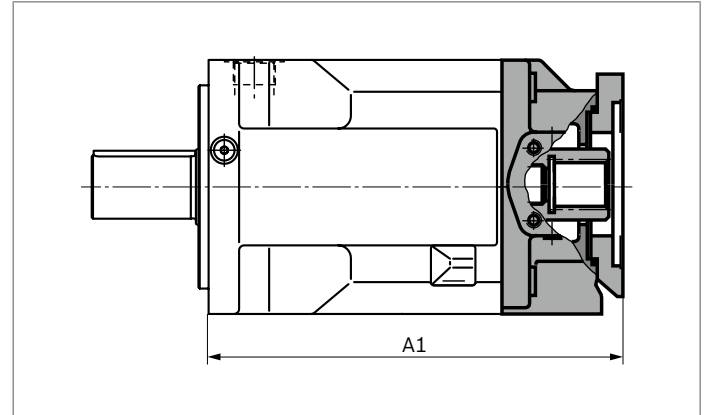

▼ **K02: Flange 101-2 (B), hub for splined shaft 7/8 in (22-4)**

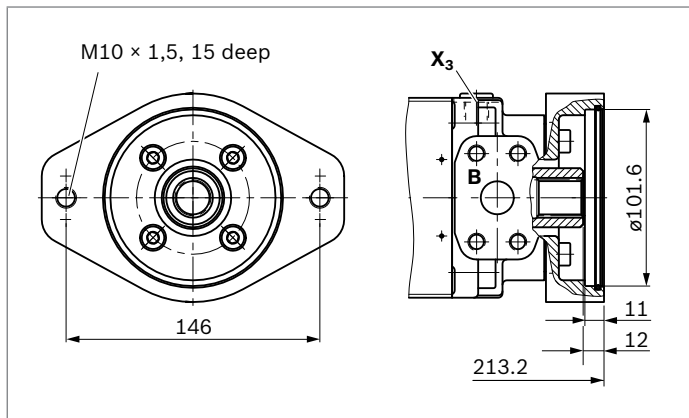

▼ **Dimensions for A1**

Code	71	125	180	250	500
K/U01	269	335	360	419	o
K/U68	300	335	360	419	o
K/UB2	269	335	360	419	o
K/UB3	269	335	360	419	o
K/UB4	294	335	360	419	o
K/UB5	299	335	360	419	o
K/UB6	-	335	360	419	o
K/UB7	-	-	373	419	500
K/U31	294	335	360	419	o
K/U33	294	335	360	419	o
K/U34	-	335	360	419	475
K/U35	-	-	-	435	511
K/U43	-	-	-	-	560
K/U99	286,5	334	359	419	497

o = on request



## Overview of attachment options

Through drive A4FO <sup>1)</sup>			Attachment of 2nd pump				
Flange	Hub for splined shaft	Code	A4VSO/G NG (shaft)	A4CSG NG (shaft)	A10V(S)O/ 31(2) NG (shaft)	A10V(S)O/52(3) NG (shaft)	External gear pump <sup>2)</sup>
<b>SAE J744</b>							
82-2 (A)	5/8 in	<b>K01</b>	–	–	–	–	AZPF
101-2 (B)	7/8 in	<b>K02, K/U68</b>	–	–	28 (S)/31	28 (S)	AZPN
<b>ISO 3019-2 (metric)</b>							
80, 2-hole	3/4 in	<b>K/UB2</b>	–	–	18 (S)/31	10 (S)	–
100, 2-hole	7/8 in	<b>K/UB3</b>	–	–	28 (S)/31	–	–
	1 in	<b>K/UB4</b>	–	–	45 (S)/31	–	–
125, 2-hole	1 1/4 in	<b>K/UB5</b>	–	–	71 (S)/31	–	–
	1 1/2 in	<b>K/UB6</b>	–	–	100 (S)/31	–	–
125, 4-hole	W32×2×14×9g	<b>K/U31</b>	40 (Z)	–	–	–	–
140, 4-hole	W40×2×18×9g	<b>K/U33</b>	71 (Z)	–	–	–	–
160, 4-hole	W50×2×24×9g	<b>K/U34</b>	125 (Z)	–	–	–	–
180, 4-hole	1 3/4 in	<b>K/UB7</b>	–	–	140 (S)/31/32	–	–
224, 4-hole	W60×2×28×9g	<b>K/U35</b>	250 (Z)	250 (Z)	–	–	–
315, 8-hole	W80×3×25×9g	<b>K/U43</b>	500 (Z)	500 (Z)	–	–	–

1) Additional through drives are available on request

2) Bosch Rexroth recommends special versions of the external gear pumps. Please contact us.

## Installation instructions

### General

The axial piston unit must be filled with hydraulic fluid and air bled during commissioning and operation. This must also be observed following a longer standstill as the axial piston unit may empty via the hydraulic lines.

Particularly in the installation position „drive shaft upwards“, filling and air bleeding must be carried out completely as there is, for example, a danger of dry running.

For sizes 22 and 28, the pump housing is internally connected to the suction chamber. A separate drain line from the housing to the reservoir is not needed. A drain line is required for sizes 71 to 500.

If a shared drain line is used for several units, make sure that the relevant case pressure is not exceeded. The shared drain line must be dimensioned to ensure that the maximum permissible case pressure of all connected units is not exceeded in any operational circumstances, particularly at cold start. If this is not possible, separate drain lines must be laid if necessary.

To achieve favorable noise values, decouple all connecting lines using elastic elements and avoid above-reservoir installation.

In all operating conditions, the suction lines and the drain lines must flow into the reservoir below the minimum fluid level. The permissible suction height  $h_s$  results from the overall loss of pressure. However, it must not be higher than  $h_{s\max} = 800$  mm. The minimum suction pressure at port **S** must not fall below 0,8 bar absolute during operation either.

When designing the reservoir, ensure that there is adequate spacing between the suction line and the drain line. This minimizes oil turbulence and carries out degassing, which prevents the heated hydraulic fluid from being sucked directly back in again.

### Installation position

See the following examples **1** to **8**.

Additional installation positions are available upon request.

### Below-reservoir installation (standard)

Below-reservoir installation is when the axial piston unit is installed outside of the reservoir below the minimum fluid level.

Installation position	Air bleeding	Filling
<b>1</b> Sizes 22, 28	Above the highest drain port <b>T<sub>1</sub></b> or <b>T<sub>2</sub></b>	<b>S</b>

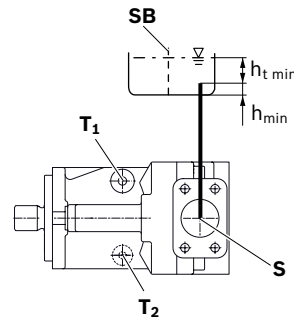

<b>2</b> Sizes 71 to 500	<b>R (L)</b>	<b>S + R (L)</b>
--------------------------	--------------	------------------

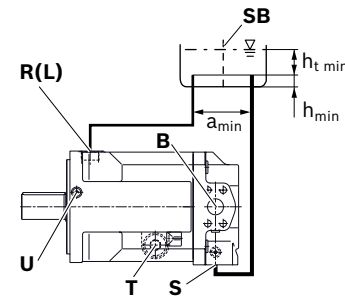

<b>3</b> Sizes 125 to 500	<b>R (L), U</b>	<b>S + R (L)</b>
---------------------------	-----------------	------------------

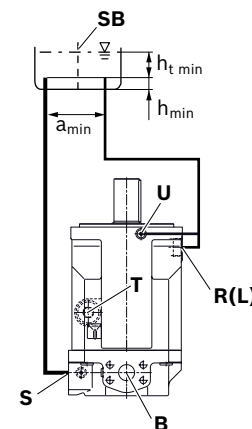

Key, see page 27.

### Inside-reservoir installation

Inside-reservoir installation is when the axial piston unit is installed in the reservoir below the minimum fluid level. The axial piston unit is completely below the hydraulic fluid.

Installation position	Air bleeding	Filling
4 Sizes 22, 28	Above the highest drain port <sup>1)</sup> <b>T<sub>1</sub></b> or <b>T<sub>2</sub></b>	

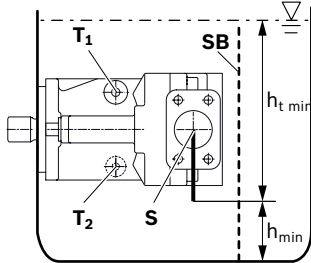

5 Sizes 71 to 500	via the highest open drain port <sup>1)</sup> <b>R (L)</b>	
-------------------	---	--

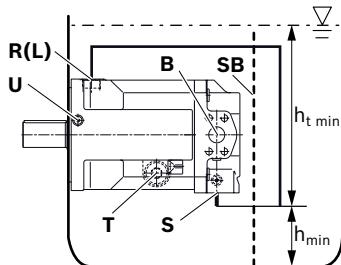

6 Sizes 125 to 500	via the highest open drain port <sup>1)</sup> <b>R (L)</b> and the bearing flushing <b>U</b>	
--------------------	---	--

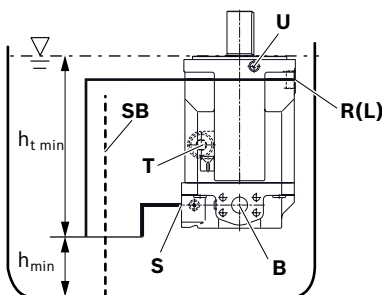

### Above-reservoir installation

Above-reservoir installation means the axial piston unit is installed above the minimum fluid level of the reservoir.

Observe the maximum permissible suction height  
 $h_{S \max} = 800 \text{ mm}$ .

Installation position	Air bleeding	Filling
7 Sizes 71 to 500	<b>F (R (L))</b>	<b>F (R (L))</b>

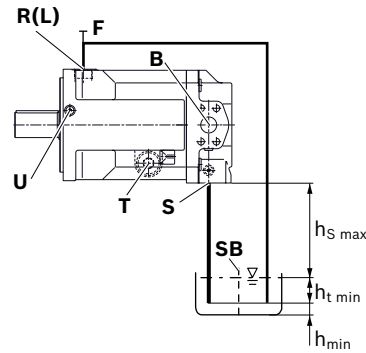

8 Sizes 125 to 500	<b>F (U)</b>	<b>F (R (L))</b>
--------------------	--------------	------------------

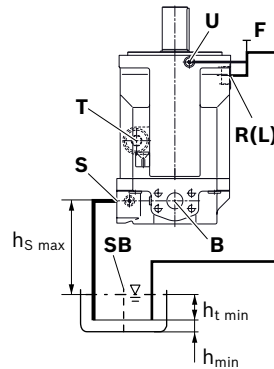

Key	
<b>T, T<sub>1</sub>, T<sub>2</sub></b>	Drain port
<b>R (L)</b>	Filling / air bleeding
<b>F</b>	Filling / air bleeding Note: F is part of the external piping
<b>S</b>	Suction port
<b>SB</b>	Baffle (baffle plate)
<b>U</b>	Flushing port
$h_{t \min}$	Minimum required immersion depth (200 mm)
$h_{\min}$	Minimum required spacing to reservoir bottom (100 mm)
$h_{S \max}$	Maximum permissible suction height (800 mm)

<sup>1)</sup> With piping: The axial piston unit must be filled before the piping is attached. Without piping: Automatically via all open ports, by position below hydraulic fluid level

## Project planning notes

- ▶ The A4FO pump is designed to be used in open circuits.
- ▶ Project planning, installation and commissioning of the axial piston units requires the involvement of skilled personnel.
- ▶ Before using the axial piston unit, please read the corresponding instruction manual thoroughly and completely. If necessary, request them from Bosch Rexroth.
- ▶ Before finalizing your design, request a binding installation drawing.
- ▶ The specified data and notes must be observed.
- ▶ Depending on the operating condition of the axial piston unit (working pressure, fluid temperature), the characteristic may shift.
- ▶ Not all versions of the product are approved for use in a safety function pursuant to ISO 13849. Please consult the responsible contact person at Bosch Rexroth if you require reliability parameters (e.g.  $MTTF_d$ ) for functional safety.
- ▶ Working ports:
  - The ports and fastening threads are designed for the specified maximum pressure. The machine or system manufacturer must ensure that the connecting elements and lines correspond to the specified operating conditions (pressure, flow, hydraulic fluid, temperature) with the necessary safety factors.
  - The working ports and function ports can only be used to accommodate hydraulic lines.

## Safety instructions

- ▶ During and shortly after operation, there is a risk of burns on the axial piston unit. Take appropriate safety measures (e.g. by wearing protective clothing).