

Powering Business Worldwide

Introduction

620 Series Piston Pump

Eaton's 620 Series piston pump signifies a stepchange in the generation of hydraulic power. Utilizing the latest developments in hydraulic pump technology, the 620 is specifically designed for moderate flow, high pressure applications.

Currently available in 74cc (4.54 in³) and 98cc (5.98 in³) displacements, the 620 is rated for 280 bar making it the ideal pump for an array of different mobile and stationary applications.

Capable of generating over 100 kW (134 hp), the 620 provides more power in a smaller, compact package. This increased power generation allows equipment manufacturers to save money by providing more hydraulic power in a smaller displacement pump. At only 288 mm (11.34 inches) in length, the 98cc fits where other pumps cannot freeing up space for other vehicle system components.

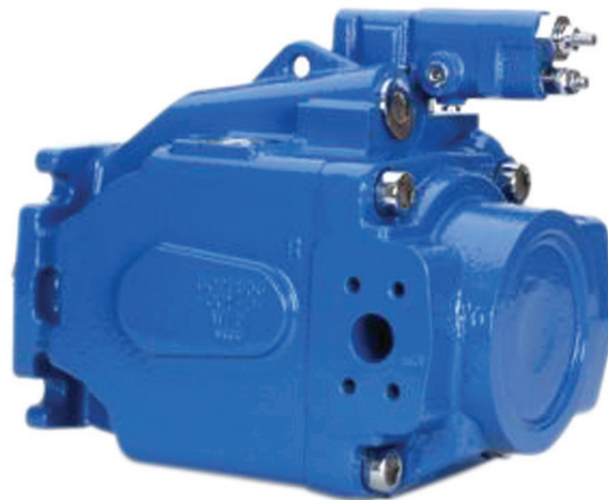

The 620 design also incorporates many new advances in product reliability. Once equipment is in the field, failures can prove to be extremely expensive by causing costly downtime. The 620 blends Eaton's long tradition in providing quality pumps with the latest design and technology methods to ensure long lasting product reliability. The result is a very simple design with 28% fewer parts and a B-10 bearing life rated to over 80,000 hours at 2,000 psi far exceeding the requirements for most applications.

Fewer parts also contributes to a lower product weight. 45.9 kg (101.3 lb), the 620 98cc is one of the lightest pumps available in its class. A lighter hydraulic pump means lower overall vehicle weight, which results in increased fuel efficiency and lower operating costs for end-users. Lower weight also makes the 620 easier to handle in assembly, maintenance and repair.

Eaton employs a unique system of tools and processes, known as Eaton Business System, to ensure quality development and delivery of the 620 product. These tools and process include such known methods as Design for Six Sigma, Lean Manufacturing and ISO certification. Our global network of manufacturing locations and distribution partners enables the 620 to be flexibly configured and delivered throughout the world.

Eaton's vision is to be our customer's preferred global supplier of fluid power components. By incorporating the latest advancements in hydraulic pump design and manufacturing, the 620 delivers greater value in terms of power and reliability.

Typical Applications

Construction

- Wheel Loaders
- Motor Graders
- Concrete Equipment
- Backhoe Loaders

Truck and Bus

- Vacuum Trucks
- Telehandler
- Refuse Trucks

Other Mobile

- Rail Maintenance
- Forestry Harvester

Oil and Gas

- Drill Rigs

Features and Benefits

- Compact size offers greater flexibility in vehicle system design
- Increased hydraulic power per displacement
- Lower maintenance costs due to longer pump life and simpler design
- Greater fuel savings due to reduced weight and high efficiency design
- Low Noise resulting from low weight and optimized valve plate

Table of Contents

Model Codes	4
Specifications and Performance	6
Control Options	
Load Sense and Pressure Compensator	7
Pressure Compensator	8
EH Inverse Proportional Pressure Control (IPPC)	9
Remote Pressure Control	10
Electronic Destroke Valve	11
Performance	
ADY074	12
ADY098	16
Pump Installation	
ADY074 C-Mount – Side-Ported	20
ADY074 C-Mount - Rear-Ported	21
ADY074 Thru-Drive SAE A Option	22
ADY074 Thru-Drive SAE B Option	23
ADY074 Thru-Drive SAE C Option	24
ADY098 C-Mount – Side-Ported	25
ADY098 C-Mount - Rear-Ported	26
ADY098 Thru-Drive SAE A Option	27
ADY098 Thru-Drive SAE B Option	28
ADY098 Thru-Drive SAE C Option	29
Control Installation	
Pressure Compensator	30
Load Sense and Pressure Compensator	31
EH Inverse Proportional Pressure Control (IPPC)	32
Electronic Destroke Valve	33
External Manual Stroke Adjustment	34
Input Shaft Options	35
Center of Gravity	37
Installation and Start-up	38

Model Codes

620 Mobile Piston Pump

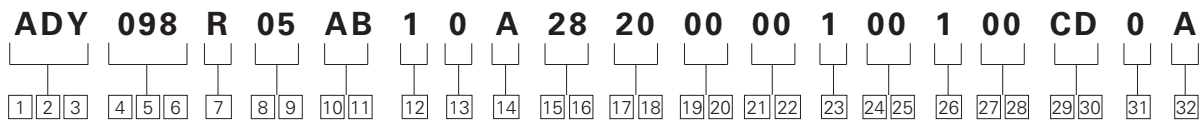

1 2 3 Pump Series

ADY – 620 Series Open
Circuit Piston Pump

4 5 6 Pump Displacement

074 – 74.4 cm³/r [4.54 in³/r]
098 – 98.0 cm³/r [5.98 in³/r]

7 Input Shaft Rotation

R – Right Hand
L – Left Hand

8 9 Front Mount and Shaft

05 – 4 Bolt C, 31.8 mm (1.25)
Dia. Keyed Shaft
06 – 4 Bolt C, 14 Tooth 12/24
Spline
07 – 4 Bolt C, 38.1 (1.50 in)
Dia Straight Keyed
08 – 4 Bolt C, 17 Tooth
12/24 Spline
10 – 4 Bolt C, 31.8 mm (1.25
in) Dia. Tapered Keyed
Shaft

10 11 Main Ports Size & Location

AA – 098 Rear Ports,
Suction 2.5" (Code 61),
Pressure 1" (Code 61).

AB – 098 Side Ports
Suction - 2.5" (Code
61); Pressure - 1" (Code
61)

AC – 098 Rear Ports, Suction
2.5" (Code 61), with
M12 Threads, Pressure
1" (Code 61) with M10
Threads

AD – 098 Side Ports
Suction - 2.5" (Code
61) with M12 Threads;
Pressure - 1" (Code 61)
with M10 Threads

AF – 074 Side Ports
Suction - 2" (Code 61);
Pressure - 1" (Code 61)

AG – 074 Rear Port, Suction
2" (Code 61) with M12
Threads, Pressure 1"
(Code 61) with M10
Threads

AH – 074 Side Ports
Suction - 2" (Code 61)
with M12 Threads;
Pressure - 1" (Code 61)
with M10 Threads

AJ – 074 Rear Ports, Suction
2" (Code 61), Pressure
1" (Code 61)

12 Case Drain Ports

1 – 1.3125 - 12 SAE O-Ring
- Top

2 – 1.3125 - 12 SAE O-Ring
- Bottom

3 – M33 x 2.0 O-Ring - Top

4 – M33 x 2.0 O-Ring -
Bottom

13 Diagnostic Pressure Ports

*Not available on thru-drive
units*

0 – No Diagnostic Pressure
Ports

1 – .5625 - 18 SAE O-Ring
- Plugged (Rear Ports
Only)

2 – M14 Plugged

14 Controller Type

A – Pressure Flow
Compensator with
.4375 - 20 SAE O-Ring
Load Sense Port

B – Pressure Flow
Compensator with
M14 Metric O-Ring
Load Sense Port

C – Pressure Compensator
Only

V – EH Inverse Proportional
Pressure Control

W – Remote Pressure
Control with .4375-20
SAE O-Ring Port, Left
Side #

15 16 Pressure Compensator Setting (Tolerance on Setting)*

08 – 76 - 84 bar
(1102 - 1218 psi)

16 – 156 - 164 bar
(2263 - 2379 psi)

20 – 196 - 204 bar
(2843 - 2959 psi)

24 – 236 - 244 bar
(3423 - 3539 psi)

28 – 276 - 284 bar
(4003 - 4119 psi)

* Additional Settings Available by Request

- Recommend RPC pressure settings
10-21 bar (140-350 psi)

Model Codes

620 Mobile Piston Pump

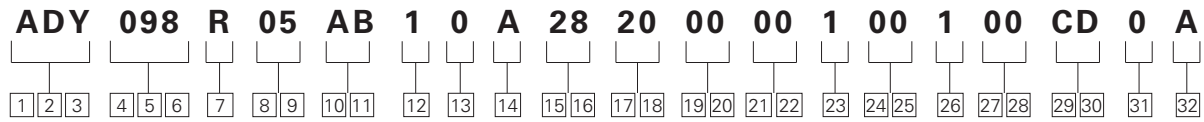

17 18 Flow Compensator/ Remote Pressure Control Setting*
(Tolerance on Setting)

- 00** – No Flow Compensator Setting
- 14** – 13 - 15 bar (189 - 218 psi)
- 20** – 19 - 21 bar (276 - 305 psi)
- 30** – 29 - 31 bar (421 - 450 psi)

19 20 Torque Control Setting

- 00** – No Torque Control

21 22 Control Special Features

- 00** – Control Special Features
- 0A** – Bleed Down Orifice
- 0B** – 24V Electronic Destroke Valve w/150 Connector Metri Pack
- 0C** – 24V Electronic Destroke Valve w/150 Connector Metri Pack and Bleed Down Orifice
- 0S** – 12V DC Solenoid AMP Jr Connector
- 0T** – 24V DC Solenoid AMP Jr Connector
- 0U** – 12V DC Solenoid Deutsch Connector
- 0V** – 24V DC Solenoid Deutsch Connector

23 Maximum Displacement Option

- 1** – Standard Displacement (As Given in Code Title)
- 2** – External Manual Stroke Adjustment

24 25 Auxiliary (Rear) Mount & Output Shaft

- 00** – No Auxiliary Mounting Features
- AA** – SAE A 2 Bolt, 9T 16/32 Spline
- AB** – SAE 2 Bolt, 11T 16/32 Spline
- AC** – SAE B 2/4 Bolt, 13T 16/32 Spline
- AD** – SAE B 2/4 Bolt, 15T 16/32 Spline
- AE** – SAE C 2/4 Bolt, 14T 12/24 Spline
- AF** – SAE C 2/4 Bolt, 17T 12/24 Spline (98cc only)
- AG** – Auxillary Mount Ready with Cover Plate

26 Shaft Seal

- 1** – Viton® Shaft Seal
- 3** – Nitrile

27 28 Pump Special Features

- 00** – No Special Features
- AA** – Auxiliary Mounting Cover Plate
- AB** – Swash Position Sensor

29 30 Paint

- 00** – No Paint
- CD** – Blue Primer

31 Identification/Packaging

- 0** – Standard Eaton Identification Box Packaging

32 Design Level

- A** – First Design

* Additional Settings Available by Request

Specifications and Performance

General Performance Specifications

		Units	ADY074	ADY098
Displacement		cc/r (in³/r)	74.4 (4.54)	98.0 (5.98)
Weight¹		kg (lbf)	43.5 (96.1)	45.9 (101.3)
Pressure²	Continuous	bar (psi)	280 (4060)	280 (4060)
	Intermittent ³		320 (4600)	320 (4600)
	Peak ⁴		350 (5000)	350 (5000)
Speed⁵	Rated	rpm	2400	2200
	Max		2880	2640
	Min		600	600
Power	Max (theoretical)	kW (hp)	83.3 (111.7)	100.6 (134.9)
	Standby		2.1 (2.8)	2.6 (3.5)
Torque	Max (theoretical)	Nm (lb-ft)	331.5 (244.5)	436.7 (322.1)
Bearing Life⁶	At 140 bar (2030 psi)	B10 Hours	125,200	81,400
	At 210 bar (3045 psi)		32,900	21,400
	At 280 bar (4060 psi)		12,100	7,900
Mass Moment of Inertia		kg-m² (lbm-ft²)	0.0089	0.0118
			(0.211)	(0.279)

- Standard SAE C non-through drive.
- The 620 is capable of running at higher pressures than shown. In order to not void the warranty, you must provide duty cycle information and receive written approval.
- Less than 10% of duty cycle.
- Momentary system pressure spikes only.
- Ratings based on Flange ports. Rated speed at 1 bar absolute [0 in Hg vac] inlet pressure and 100% displacement. For Max Speed see inlet pressure vs. speed charts.
- Bearing life ratings at rated speed – 1 bar abs (0 psig) inlet. Will vary based on thrust and side loads. For additional information, contact EATON engineering

Inlet Pressure, Case Pressure, and Operating Temperature Requirements

Inlet Pressure			Case Pressure			Operating Temperature		
Rated bar abs (psig)	Minimum bar abs (in. Hg)	Maximum bar abs (psig)	Maximum Continuous bar abs (psig)	Maximum Intermittent bar abs (psig)	Peak bar abs (psig)	Rated °C (°F)	Minimum Temperature °C (°F)	Maximum Intermittent °C (°F)
1.0 (0)	0.85 (5)	4.4 (50)	1.3 (5)	3.1 (30)	6.2 (75)	93 (200)	-25 (-13)	104 (220)

Hydraulic Fluids

Fluid	Recommended Operating Viscosity Range cSt (SUS)	Maximum Continuous cSt (SUS)	Maximum Viscosity at Startup cSt (SUS)	Minimum Viscosity @ Max. Intermittent Temperature of 93°C (200°F) cSt (SUS)	Minimum Intermittent cSt (SUS)
Use antiwear hydraulic oil, or automotive type crankcase oil (designations SC, SD, SE or SF) per SAE J183 FEB80	16 to 40 (80 to 188)	430 (1192)	2100 (9720)	10 (59)	6 (46)

For more information, see Eaton publication 579. For operation on other alternative or environmentally friendly fluids, please contact your Eaton Representative.

Control Options

Load Sense and Pressure Compensator

Load Sense and Pressure Compensator Control

The pump will provide power matching of pump output to system load demand, maximizing efficiency and improving load metering characteristics of any directional control valve installed between the pump and the load.

Load sensing ensures that the pump always provides only the amount of flow needed by the load. At the same time, the pump operating pressure adjusts to the actual load pressure plus a pressure differential required for the control action. When the system is not demanding power, the load sense control will operate in an energy-saving stand-by mode.

Typically, the differential pressure is that between the pressure inlet and service port of a proportionally controlled directional valve, or a load sensing directional control valve. See the model code on page 4 for differential pressure settings for load sensing.

If the load pressure exceeds the system pressure setting, the pressure compensator de-strokes the pump. The load sensing line must be as short as possible and can also be used for remote control or unloading of the pump pressure. For remote control purposes, it is recommended that you contact your Eaton Representative for the correct configuration of the control.

Warning: 1) When adjusting the pressure limiter, install a 0 to 350 bar (0 to 5000 psi) gage in the outlet gage port and limit the pressure setting to the continuous rated pressure for the pump displacement shown on page 6. It is possible to adjust the pressure compensator beyond the rated pressure of the pump. Doing so, may void the warranty of the 620 pump. 2) EATON recommends use of relief valve in all systems

Pressure Compensator Spring Pressure Ranges:

60 bar (870 psi) to 144 bar (2089 psi)
144 bar (2089 psi) to 280 bar (4060 psi)

Flow Compensator (Load Sense) Spring Pressure Range:

10.3 bar (150 psi) to 17.2 bar (250 psi)
17.2 bar (250 psi) to 31.0 bar (450 psi)
31.0 bar (450 psi) to 41.4 bar (600 psi)

Typical Operating Curve

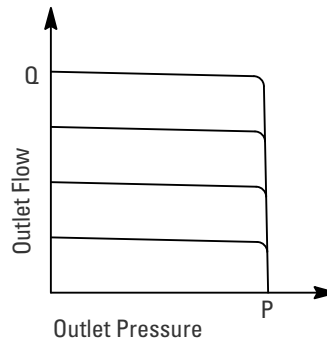

Dynamic Response per SAE J745 (Using Swash Plate Position)

	Response (off stroke)	Recovery (on stroke)	Load Sense Recovery
	msec	msec	msec
ADY074	30	90	155
ADY098	30	70	125

Optional bleed-down orifice with control special feature "0A". \varnothing 0.4 mm (.015 in.). Orifice is plugged for no bleed down in control.

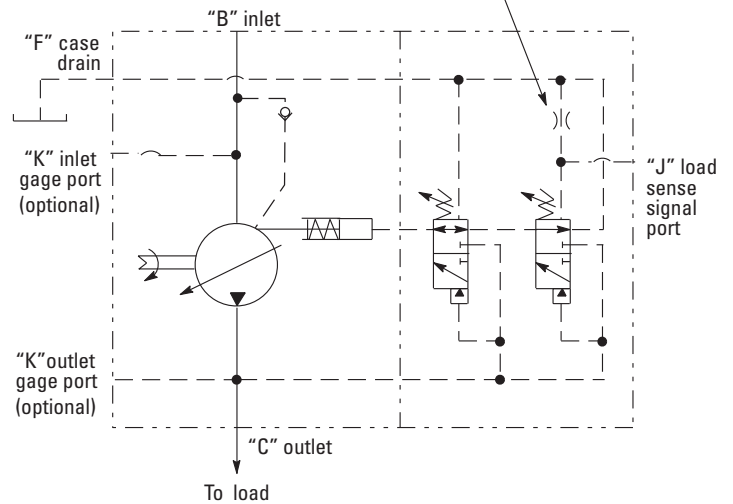

Control Options

Pressure Compensator

Pressure Compensator Control

The pump will provide a continuously modulated flow to meet changing load demands at a pre-adjusted compensator pressure. At pressures below the compensator setting, the pump will operate at maximum displacement. See model code on page 4 for compensator pressure ranges.

Warning: 1) When adjusting the pressure limiter, install a 0 to 350 bar (0 to 5000 psi) gage in the outlet gage port and limit the pressure setting to the continuous rated pressure for the pump displacement shown on page 6. It is possible to adjust the pressure compensator beyond the rated pressure of the pump. Doing so, may void the warranty of the 620 pump. 2) EATON recommends use of relief valve in all systems.

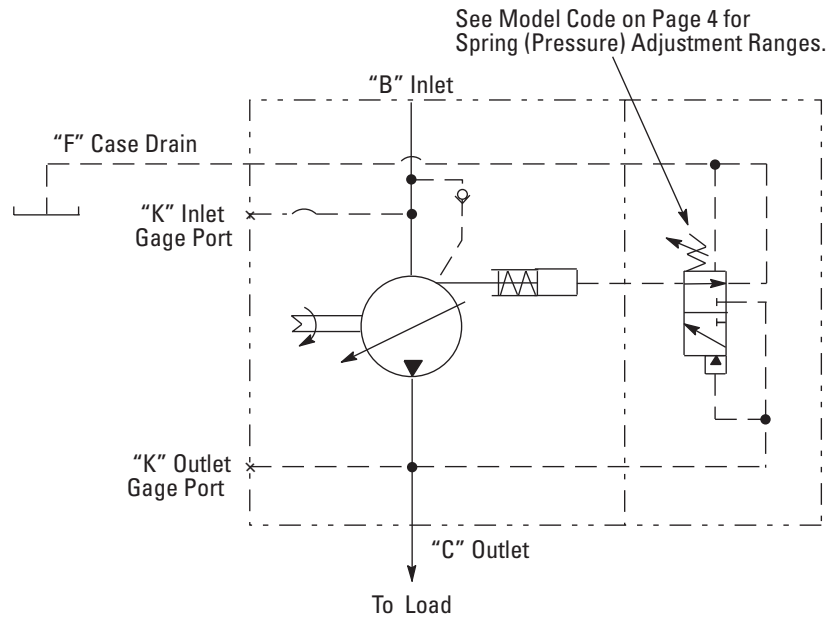

Pressure Compensator Spring Pressure Ranges:

60 bar (870 psi) to 144 bar (2089 psi)
 144 bar (2089 psi) to 280 bar (4060 psi)

Pressure Cut-off Characteristics of Pressure Compensator Control

@ 49°C (120°F),
 Static Conditions.

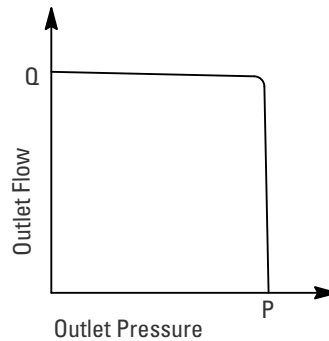

Dynamic Response per SAE J745 (Using Swash Plate Position)

	Response (off stroke)	Recovery (on stroke)
	msec	msec
ADY074	30	90
ADY098	30	70

Control Options

EH Inverse Proportional Pressure Control (IPPC)

EH Inverse Proportional Pressure Control (IPPC)

The EH Inverse Proportional Pressure control allows for stepless variation of the max pump output pressure, as per the current signal provided to the control valve solenoid.

The integrated pump control makes use of an external current signal to vary the pump output pressure

This control has an inverse proportional characteristic i.e. with increasing current signal, the max output pressure is proportionately reduced

Warning: The pressure setting may be adjusted beyond the rated pressure of the pump. When adjusting the pressure, install a 0-350 bar (0-5000 psi) gage in the outlet gage port and limit the pressure setting to the continuous rated pressure for the pump displacement shown on page 6.

Pressure Limit Settings

The EH IPPC covers pressure range of the ADU pumps. The max pressure can be set from 140 bar (2050 psi) to 280 bar (4060 psi).

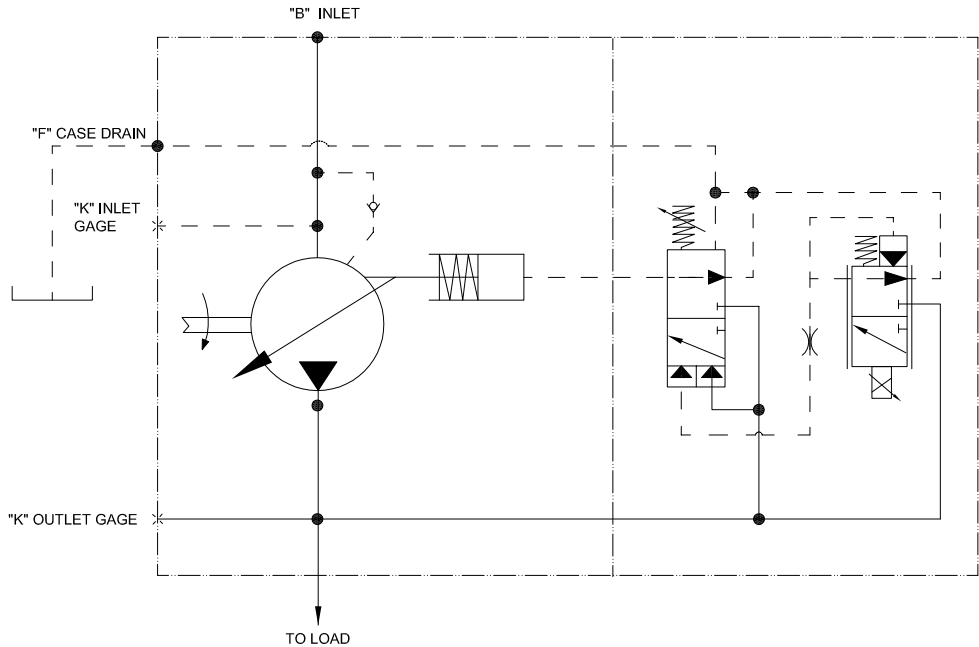

Typ. Current vs Pressure Characteristics of IPPC at 1800 rpm at various max pressure settings at 49 deg C (120deg F), static conditions.

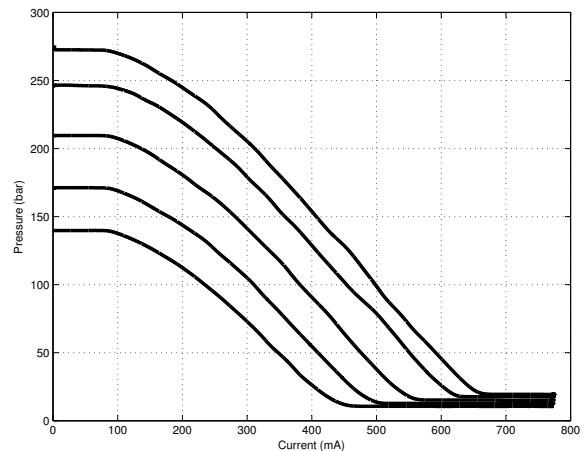

Electrical data

Voltage	12 V	24 V
Max Current	1500 mA	750 mA
R20, Resistance (ohm)	5.3 +/- 5%	21.2 +/- 5%
Type of Control	Current	Current
Recommended PWM Control Frequency	100 Hz	100 Hz
Duty Cycle	100%	100%
Insulation material	Class H, 180 deg C	Class H, 180 deg C
Protection Class	IP6K6/IPX9K	IP6K6/IPX9K
Connector	AMP Junior Power Timer/ Deutsch Connector DT04-2P	AMP Junior Power Timer/ Deutsch Connector DT04-2P
Operating Temperature	-30 deg C; 105 deg C	-30 deg C; 105 deg C

Control Options

Remote Pressure Control

Remote Pressure Control

Remote relief valve is to be connected to pilot port "J" through necessary external piping. Standard differential pressure of 20 bar is set at RPC spool. The required outlet pressure (below 280 bar) can be set by adjusting remote relief valve setting. Once pressure reaches pre-set value, flow across remote relief valve starts, this results in RPC spool movement due to pressure imbalance. This will de-stroke the pump to maintain the set pressure.

Secondary pressure compensator is provided to limit the max pressure setting as a fail safe measure. The delta pressure is factory set which can not be changed.

*** Flow Compensator is not available with RPC.**

*** Flow Compensator/ Remote Pressure Control setting should be selected within range of 10-24 bar (140-350 psi).**

*** Remote relief valve is not included in supply scope of the pump.**

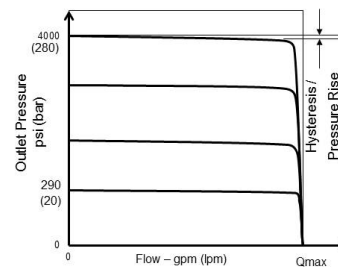
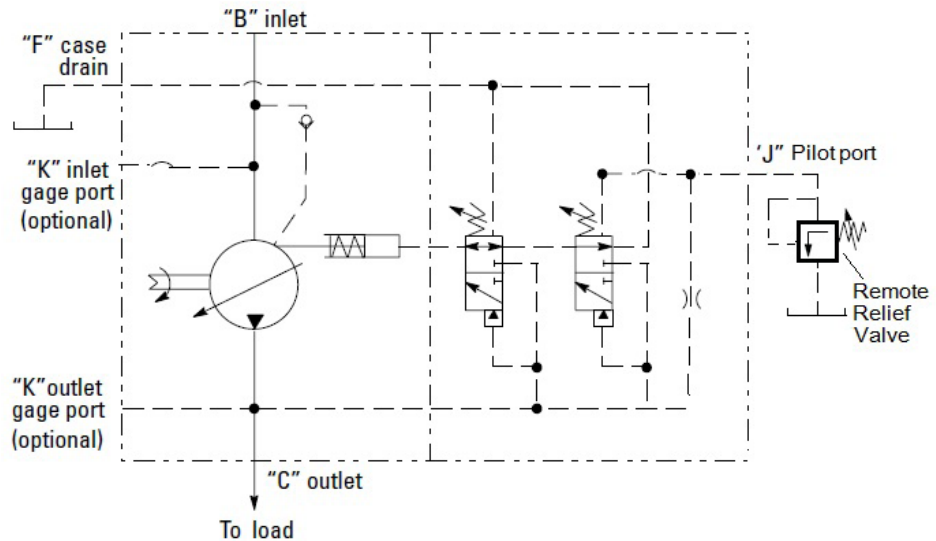

Delta Pressure setting at control valve - bar (psi)	14 - 24 (200 - 350)
Control fluid consumption - lpm (gpm)	4.5 (1.2) max.
Recommended flow rating of remote relief valve- lpm (gpm)	3 - 5 (0.8 - 1.32)
Recommended Eaton Relief Valve part number	RV5-10-S-0-50

Control Options

Electronic Destroke Valve

Electronic Destroke Valve

The 620 Electronic Destroke Valve reduces pump start-up torque by directing outlet pressure to the control piston.

It is primarily used in cold weather applications and includes a 12 or 24 VDC directional control valve mounted between the pump housing and compensator.

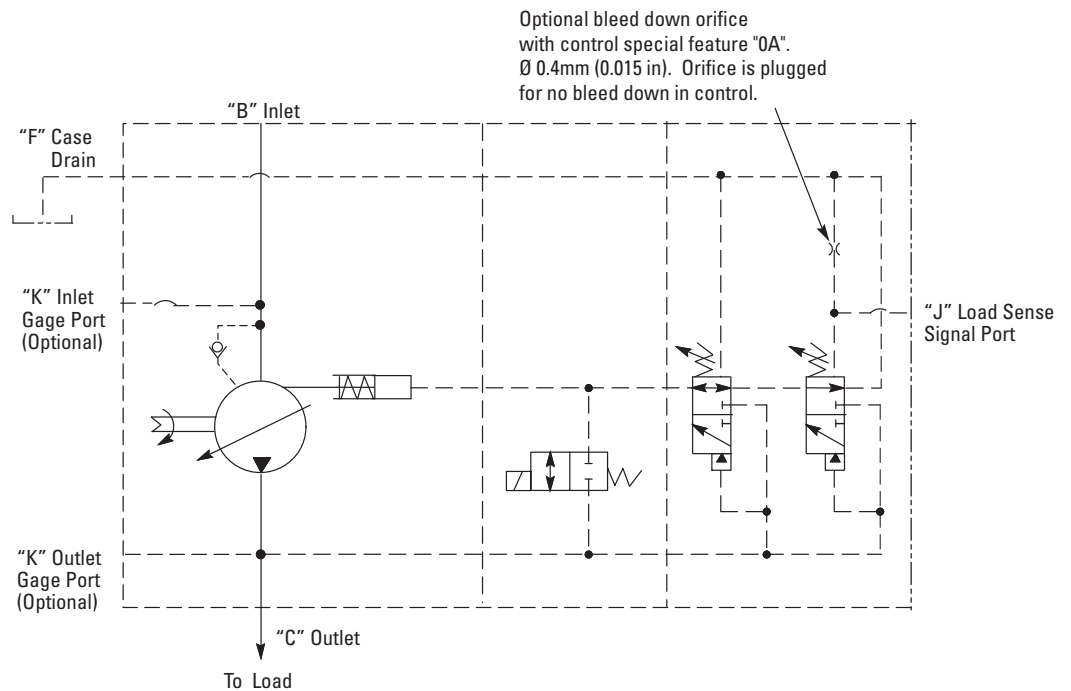

Performance

ADY074

Overall Efficiency Versus Speed @ 49°C (120°F), Full Flow, and 1.0 bar (0 psi) Inlet

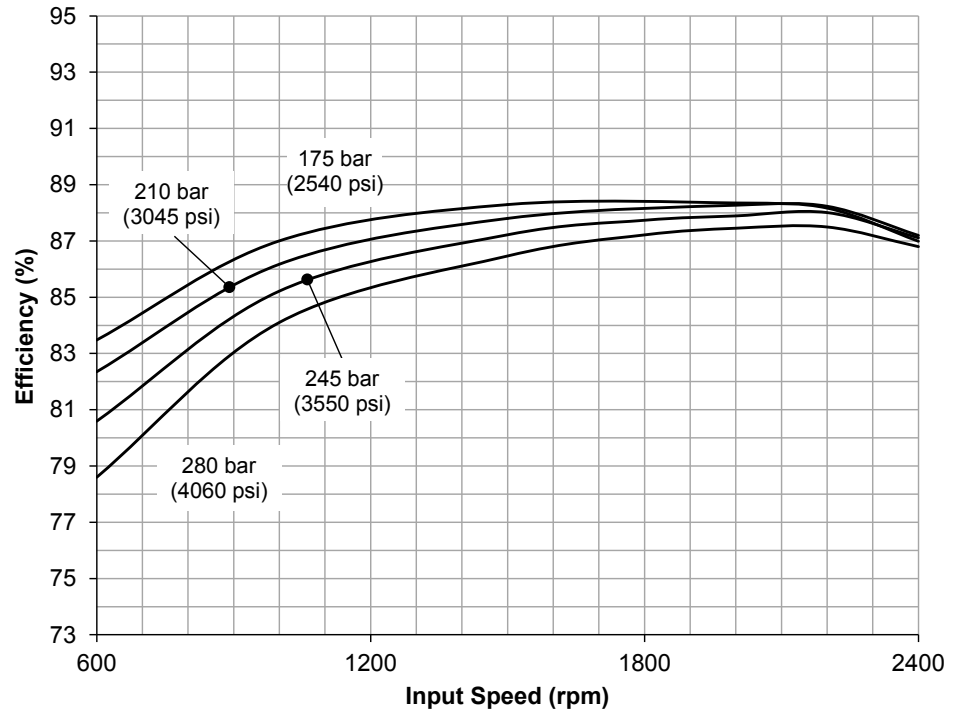

Overall Efficiency Versus Speed @ 49°C (120°F), Full Flow, and 1.0 bar (0 psi) Inlet

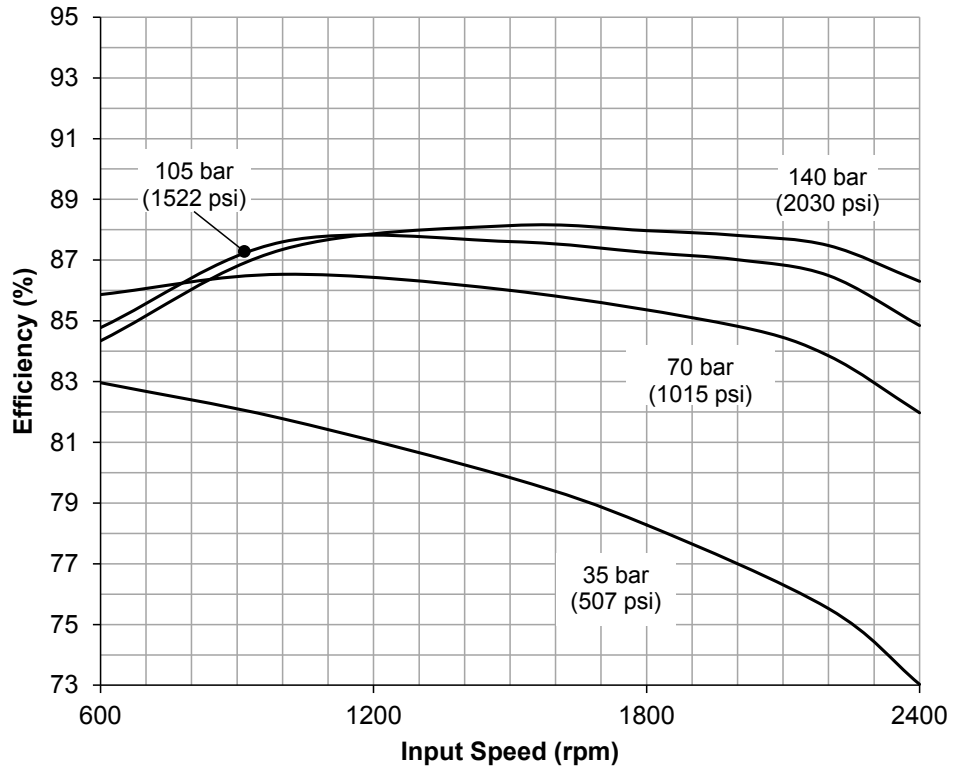

Performance

ADY074

**Input Torque Versus Speed
@ 49°C (120°F), Full Flow,
and 1.0 bar (0 psi) Inlet**

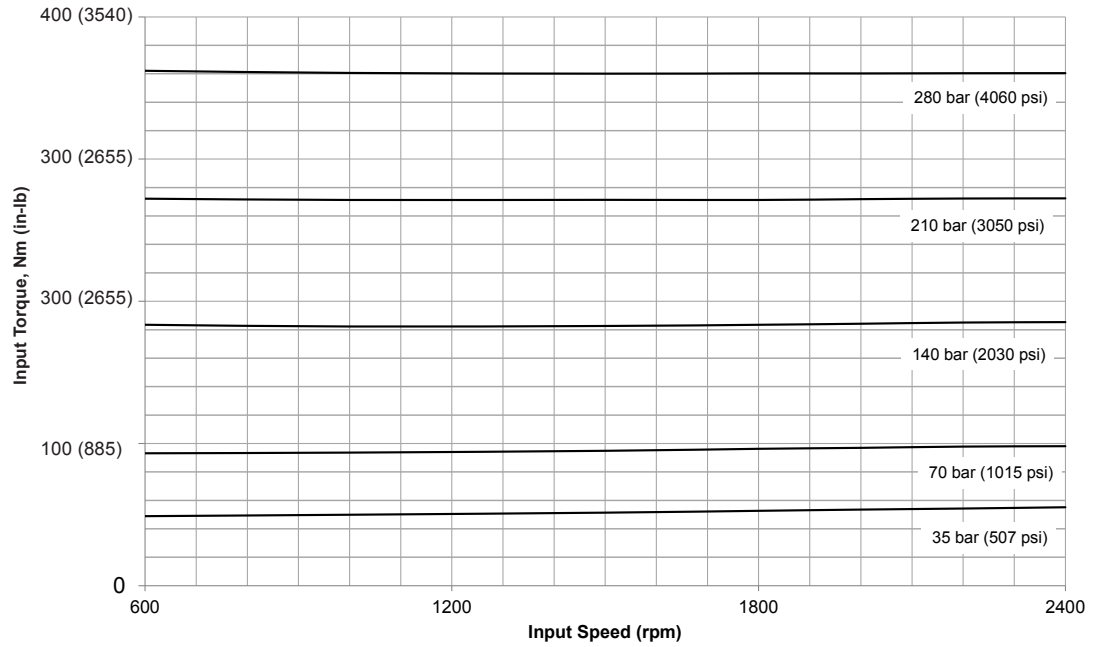

**Input Power Versus Speed
@ 49°C (120°F), Full Flow,
and 1.0 bar (0 psi) Inlet**

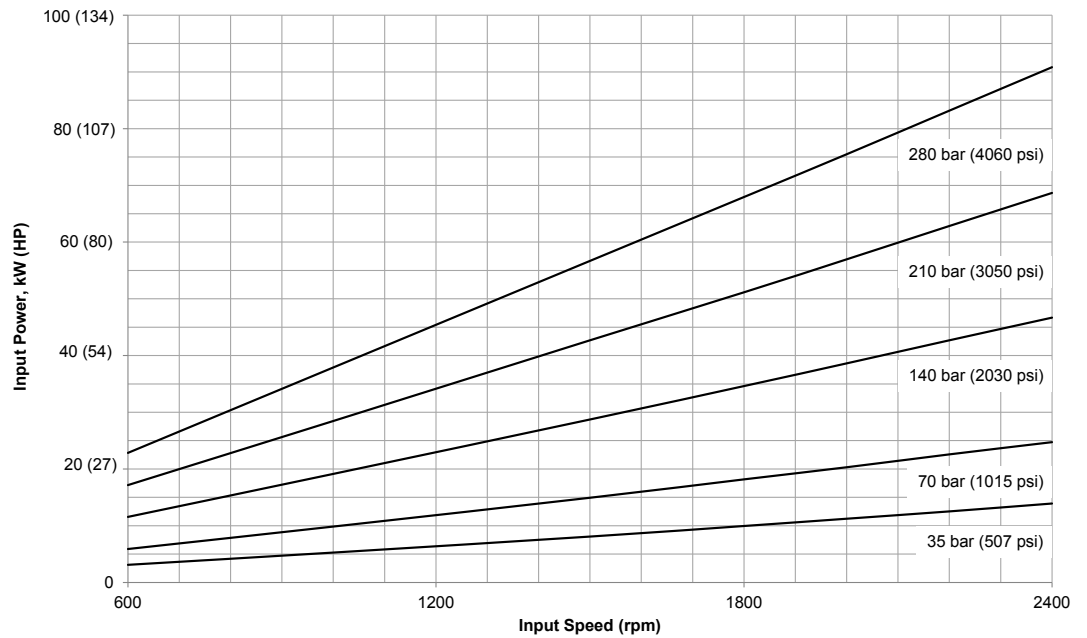

Performance

ADY074

Delivery and Case Flow Versus Speed @ 49°C (120°F)

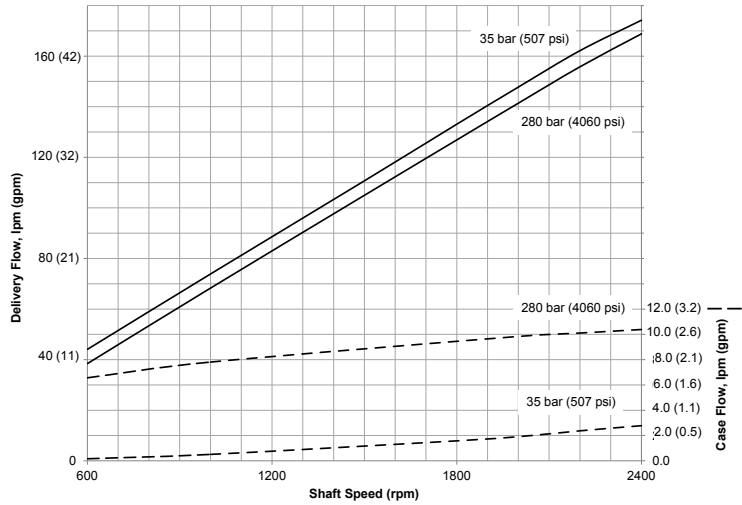

Input Torque and Case Flow vs. Speed @ Stand-by and 49°C (120°F)

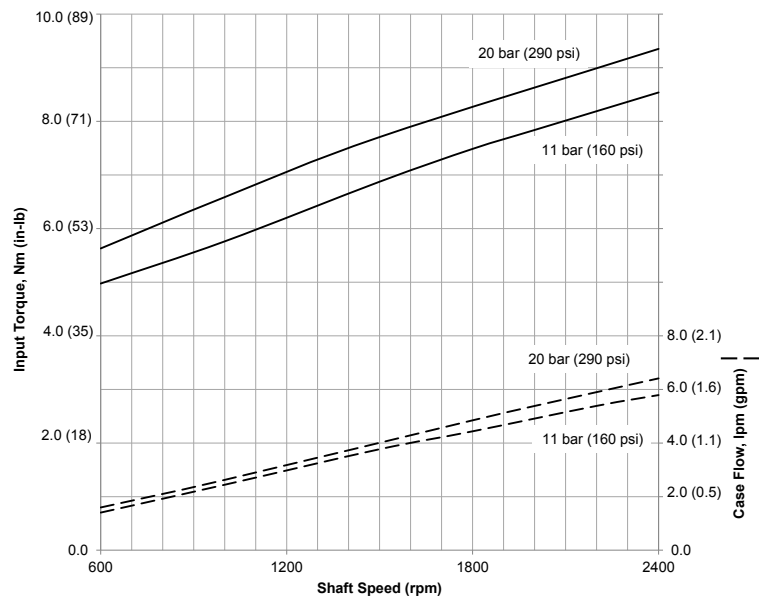

Input Torque and Case Flow vs. Speed @ Cut-off and 49°C (120°F)

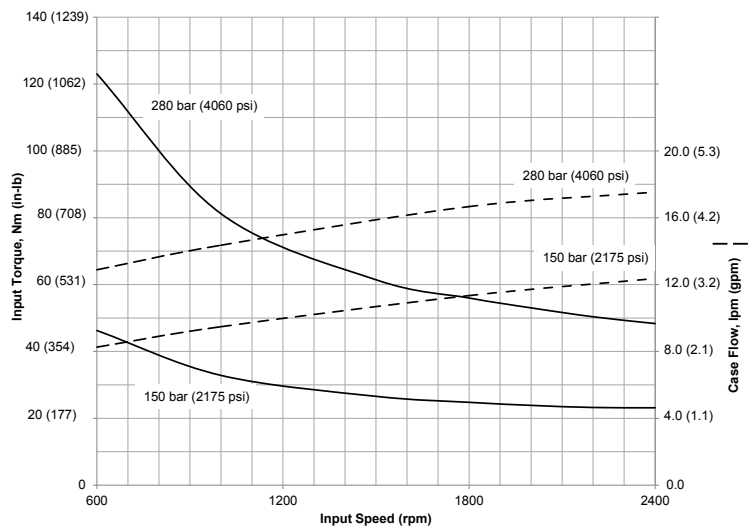

Performance

ADY074

Inlet Pressure vs. Speed @ 49°C (120°F)

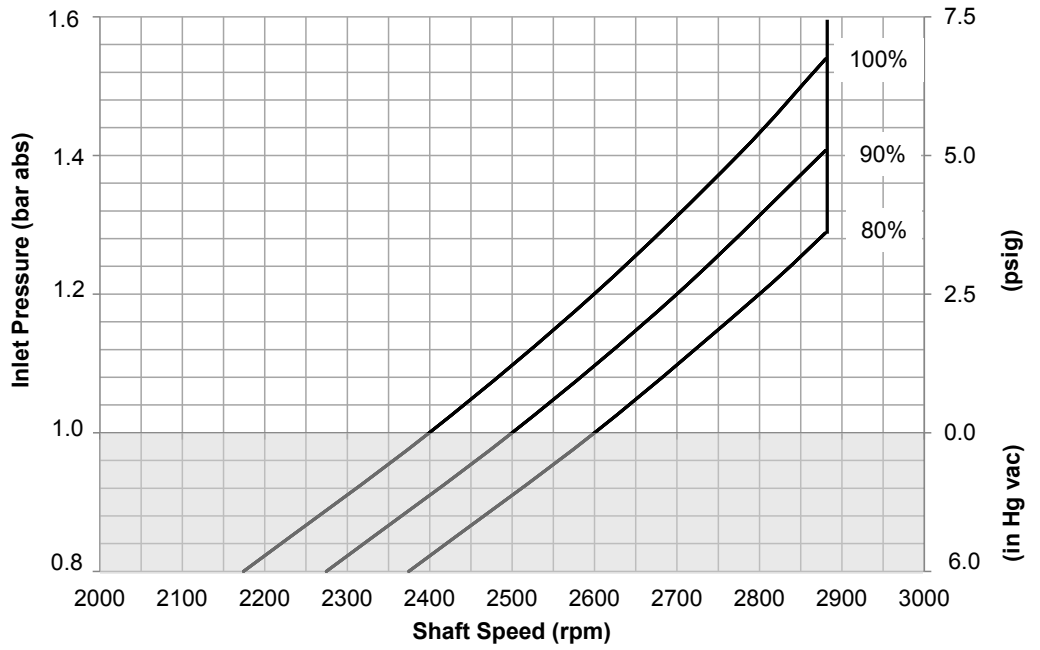

Typical Sound Pressure Level vs. Pressure @ 49°C (120°F) and 1.0 bar absolute (0 psi gauge) Inlet (Per ISO 4412)

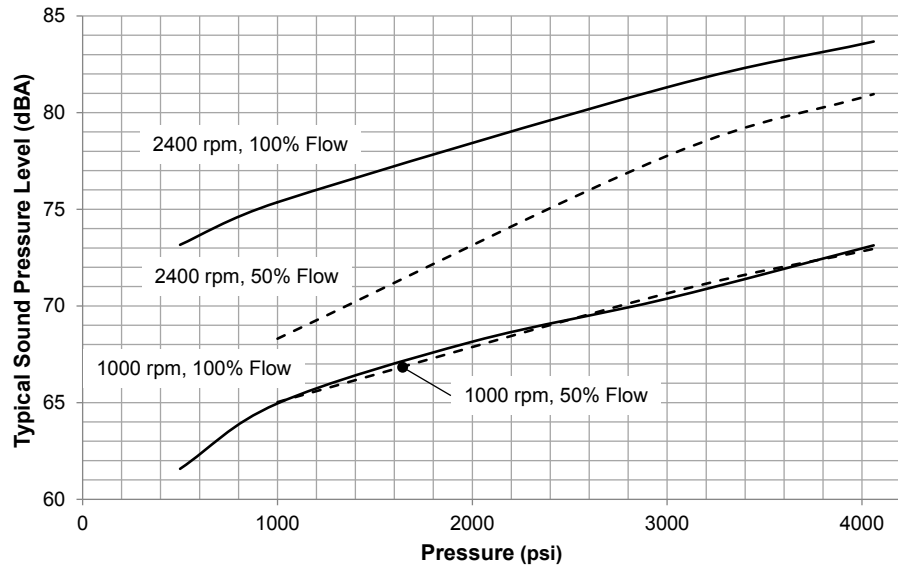

Performance

ADY098

Overall Efficiency Versus Speed @ 49°C (120°F), Full Flow, and 1.0 bar (0 psi) Inlet

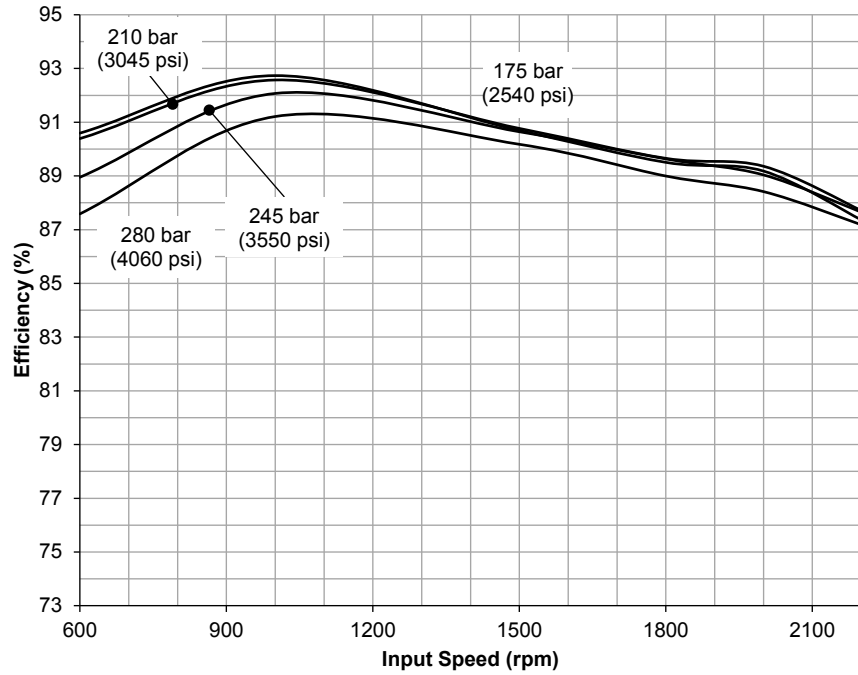

Overall Efficiency Versus Speed @ 49°C (120 F), Full Flow, and 1.0 bar (0 psi) Inlet

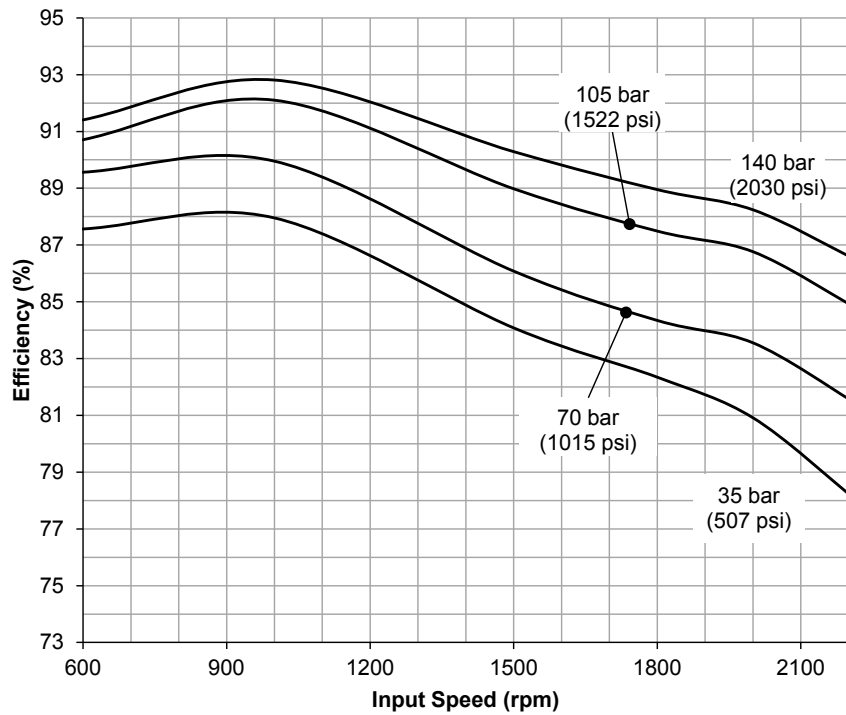

Performance

ADY098

Input Power Versus Speed @ 49°C (120°F), Full Flow, and 1.0 bar (0 psi) Inlet

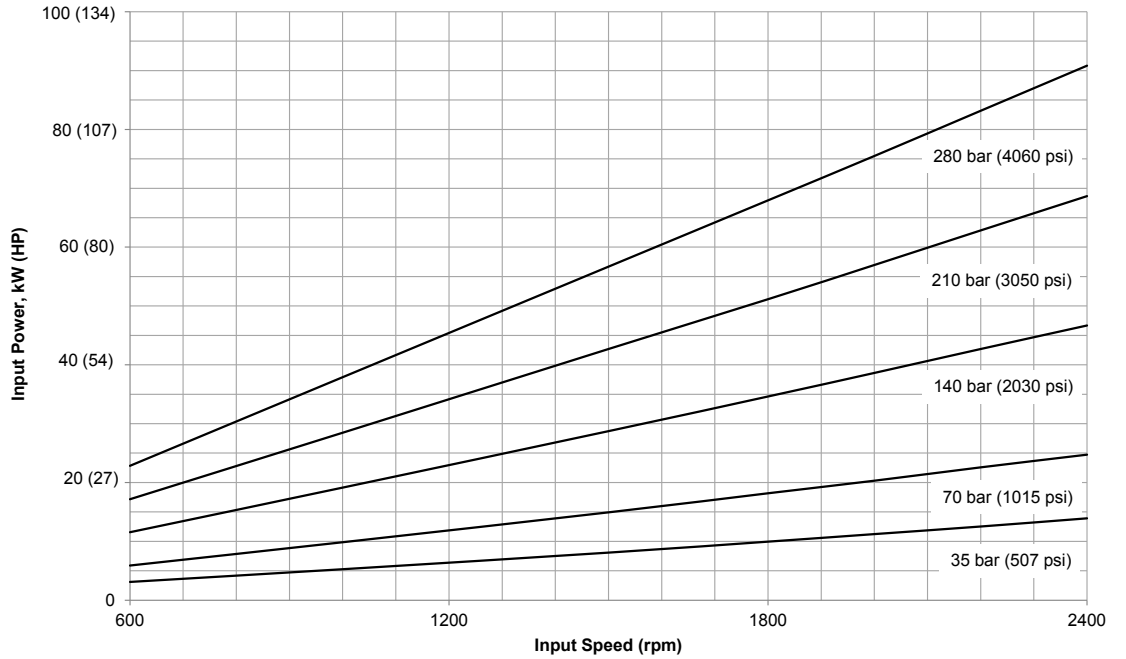

Input Torque Versus Speed @ 49°C (120°F), Full Flow, and 1.0 bar (0 psi) Inlet

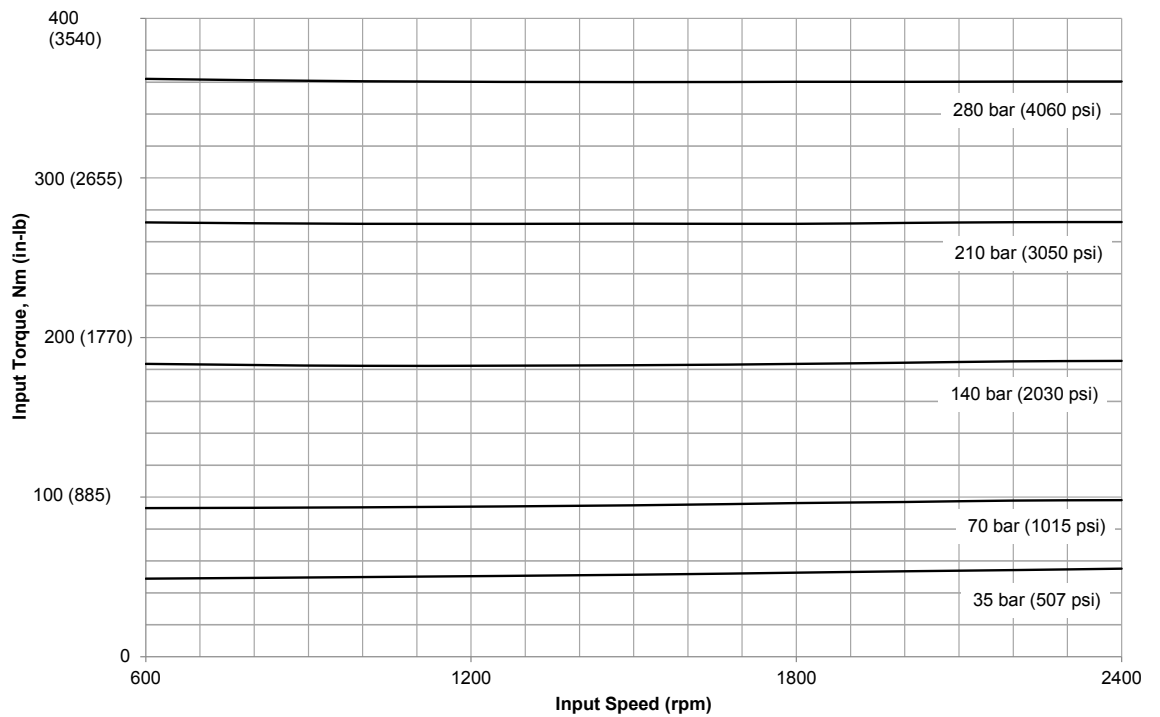

Performance

ADY098

Delivery and Case Flow Versus Speed @ 49°C (120°F)

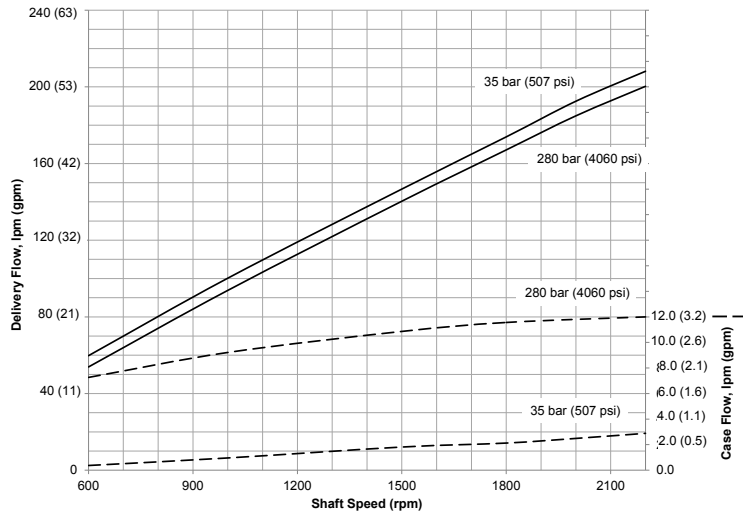

Input Torque and Case Flow Stand-by @ 49°C (120°F)

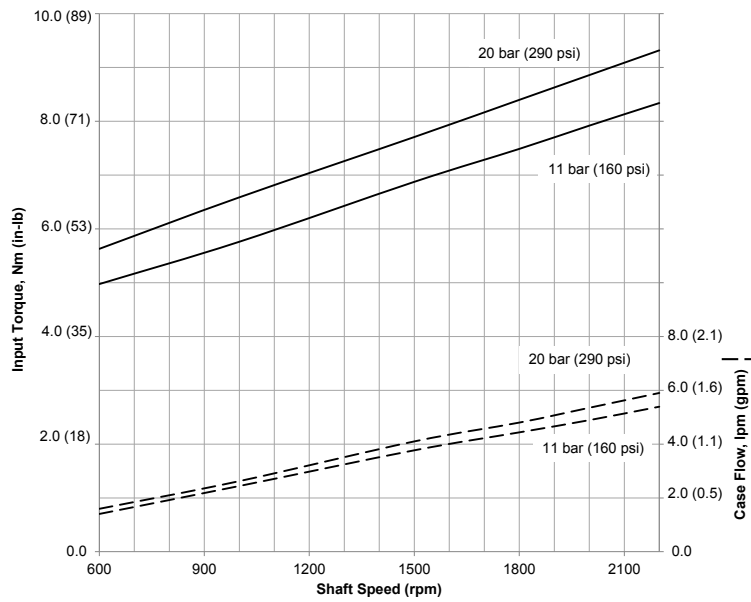

Input Torque and Case Flow Cut-off @ 49°C (120°F)

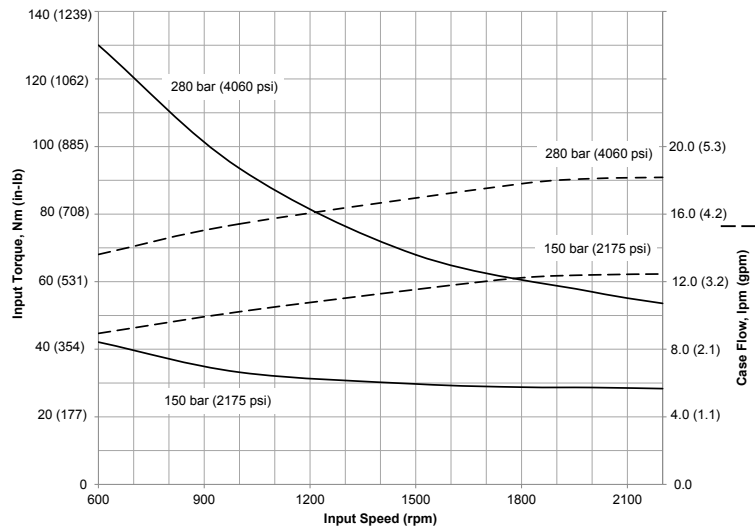

Performance

ADY098

Inlet Pressure Versus Speed @ 49°C (120°F)

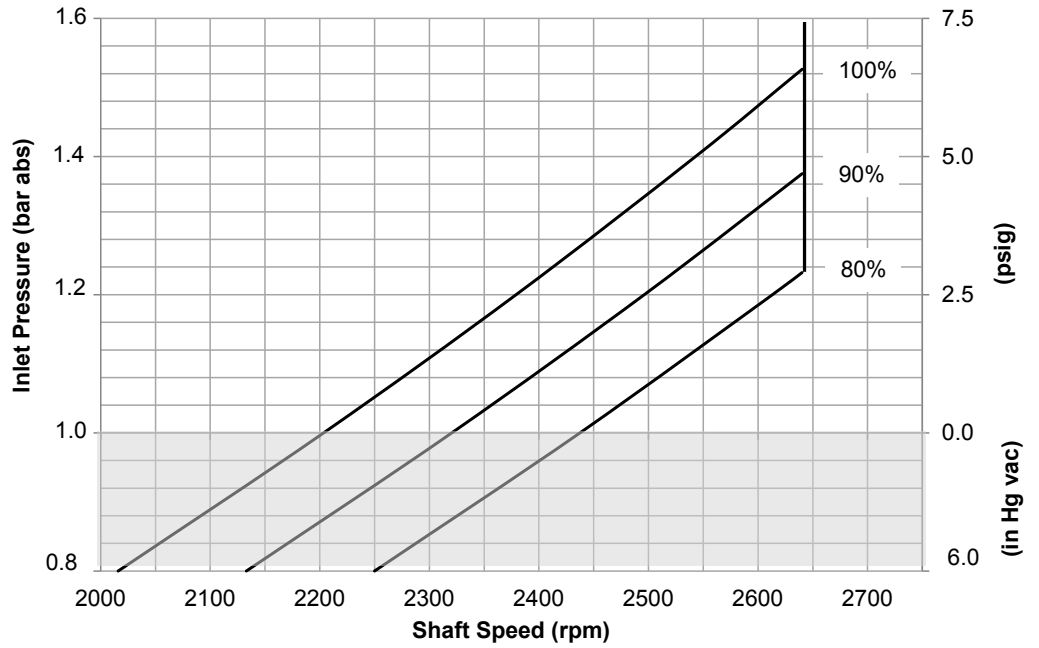

Typical Sound Pressure Level vs. Pressure @ 49°C (120°F) and 1.0 bar absolute (0 psi gauge) Inlet (Per ISO 4412)

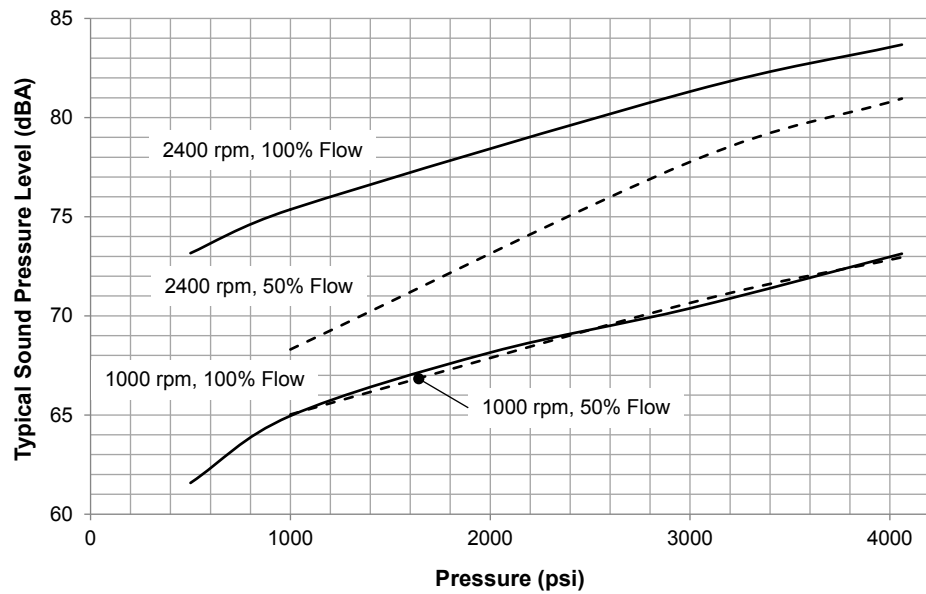

Pump Installation

ADY074 C-Mount /Side-Ported with Load Sense and Pressure Compensator Control

RH Rotation

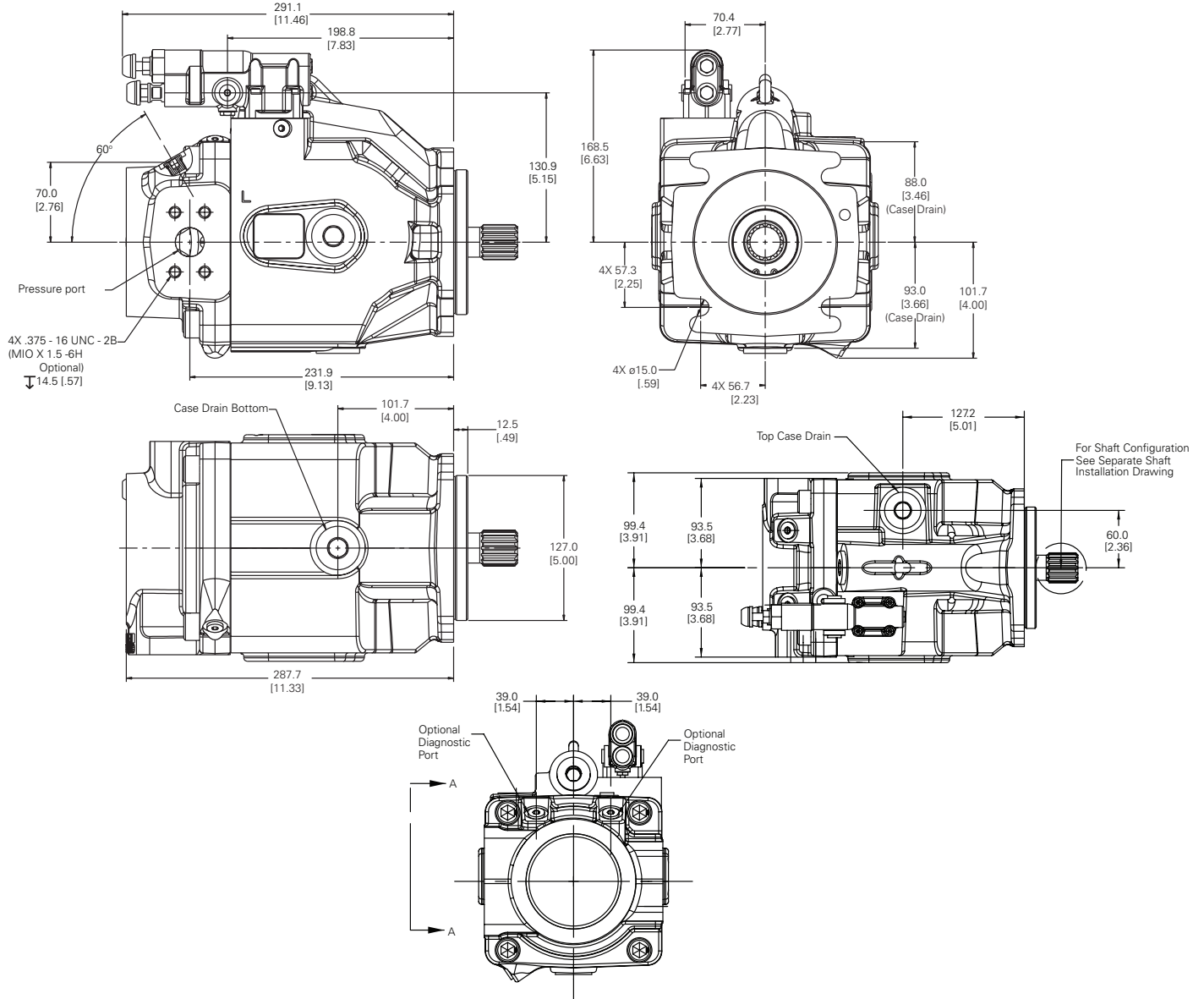

View A-A

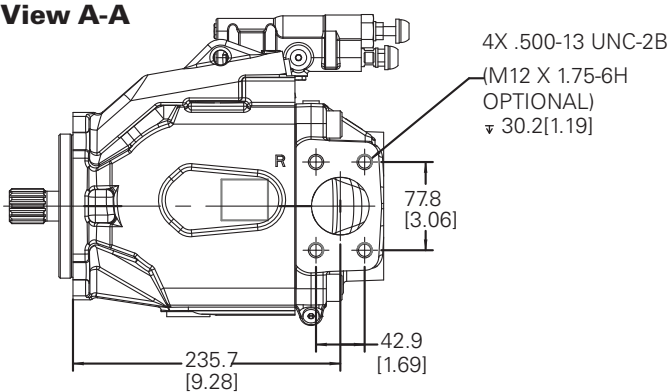

LH Rotation

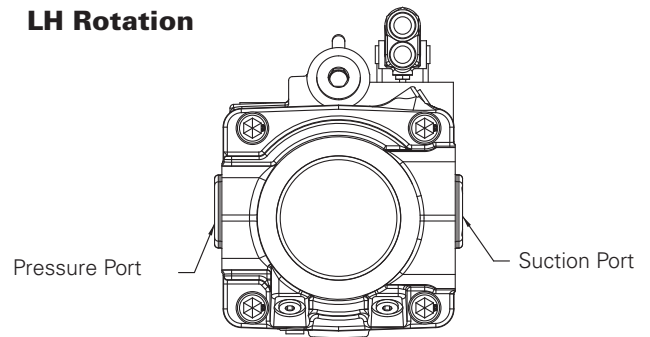

Pump Installation

ADY074 C-Mount /Rear-Ported with Load Sense and Pressure Compensator Control

RH Rotation

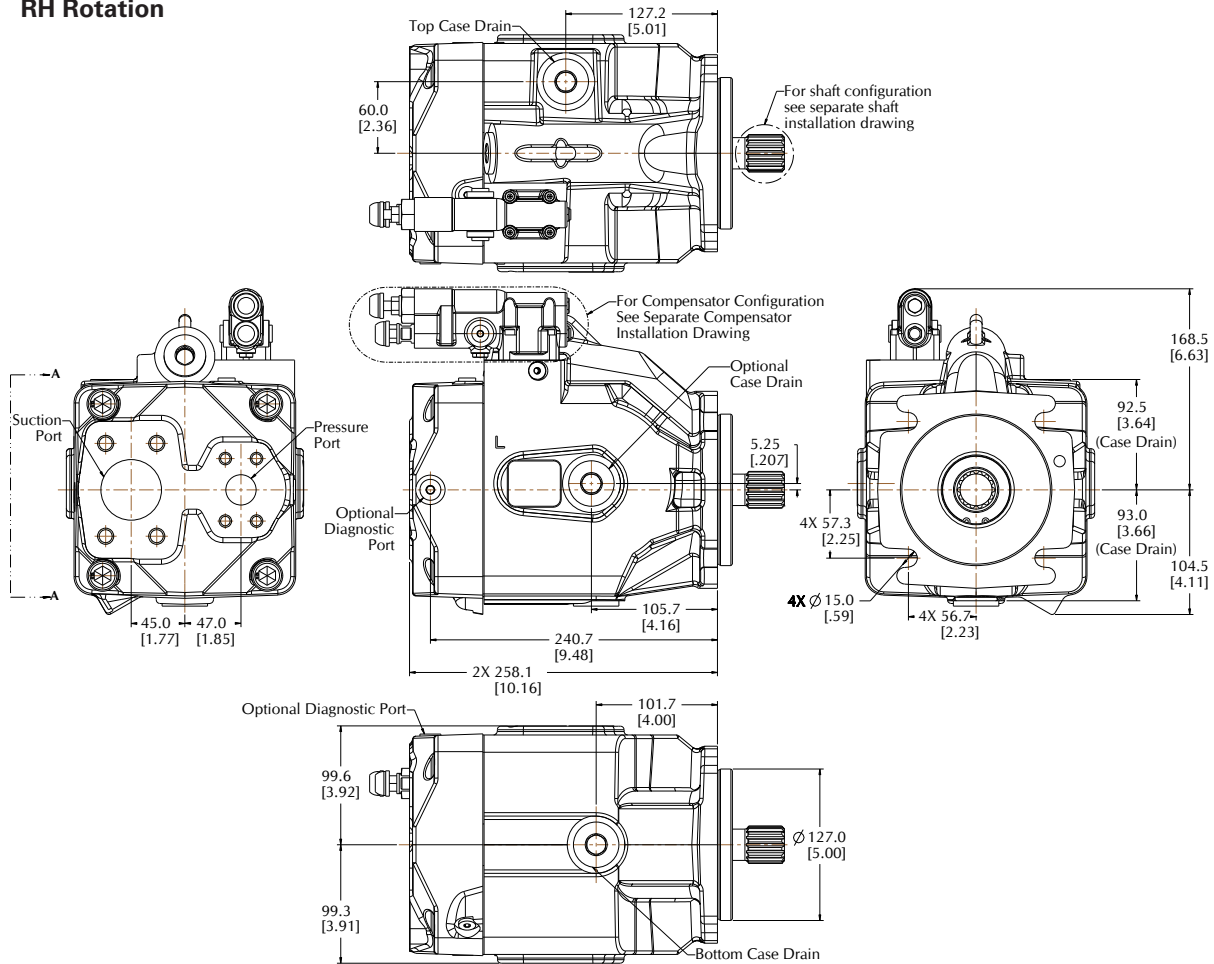

View A-A

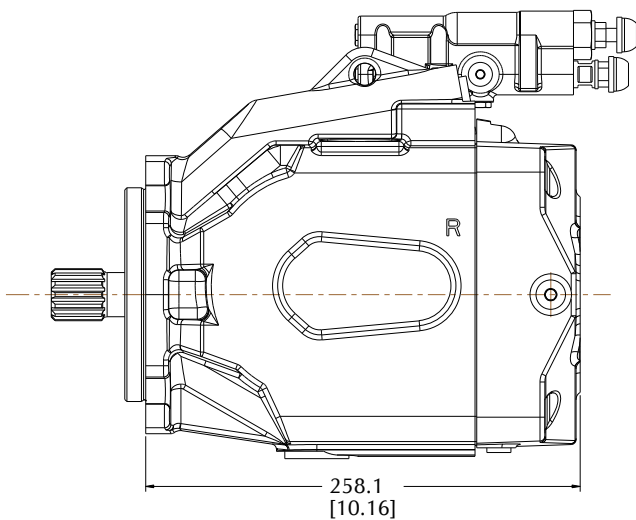

LH Rotation

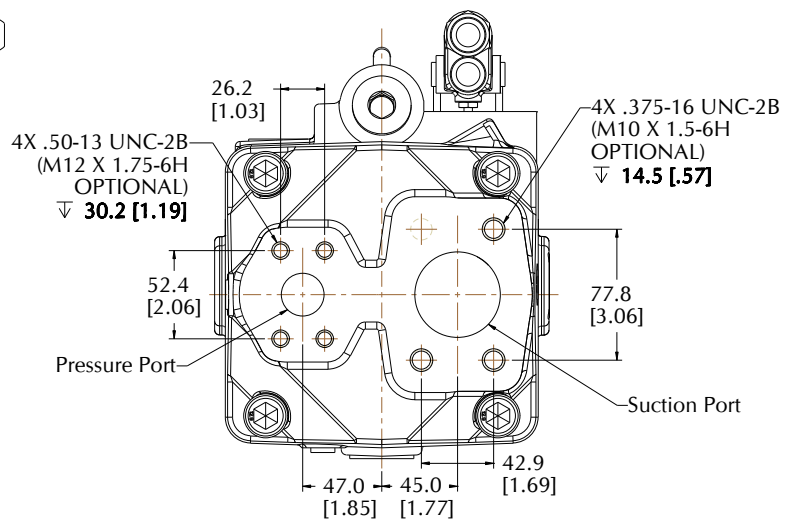

Pump Installation

ADY074 Thru-Drive SAE A

Thru-Drive SAE A

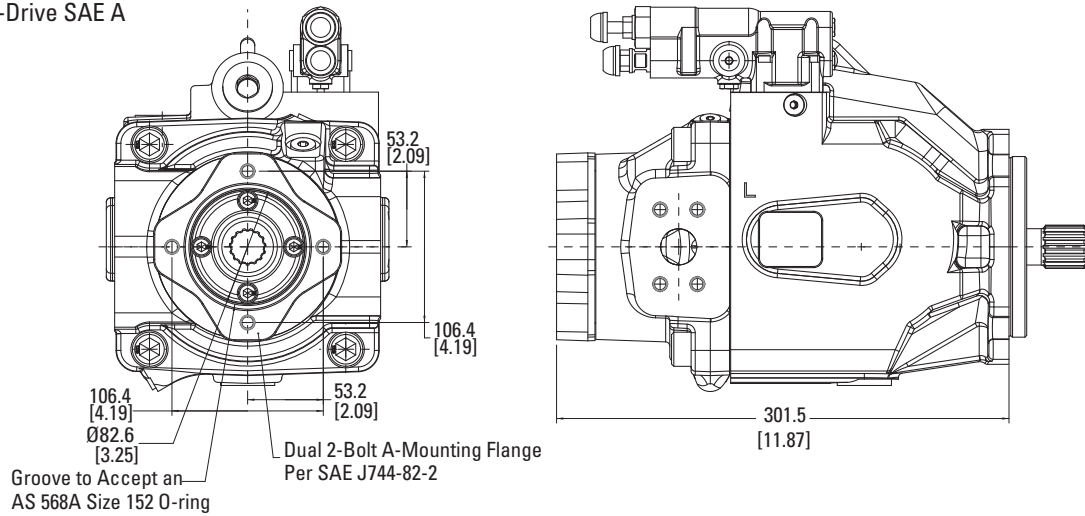

A Thru-Drive Cover Plate Installation

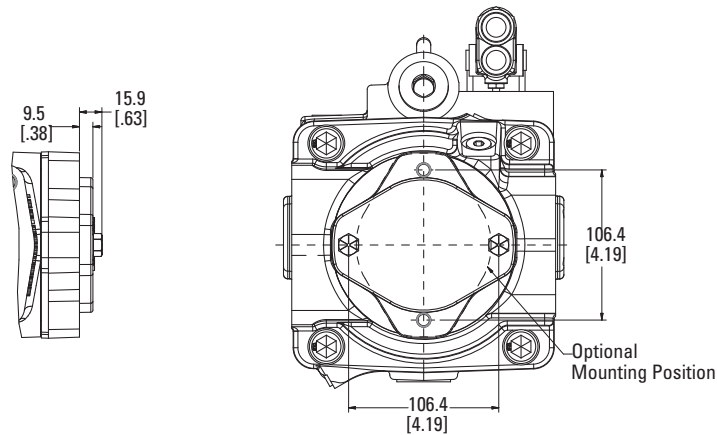

Output Shaft Installation 9T Spline

Maximum Torque
58 Nm [513 in-lbf]

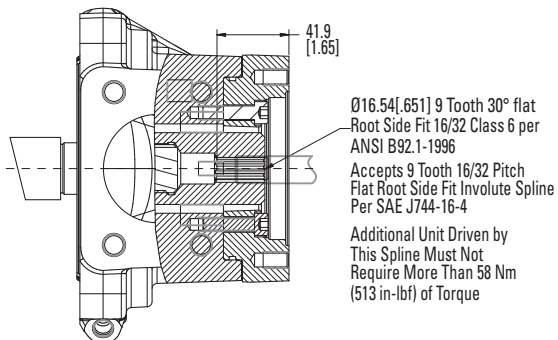

Output Shaft Installation 11T Spline

Maximum Torque
124 Nm [1100 in-lbf]

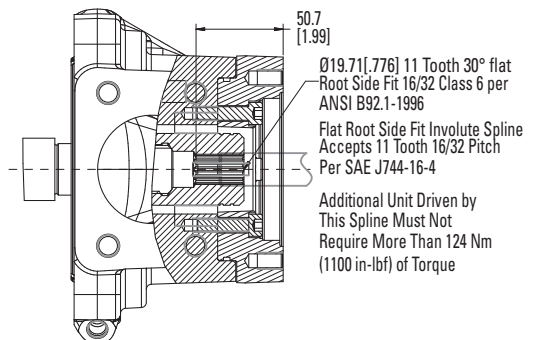

Pump Installation

ADY074 Thru-Drive SAE B

Thru-Drive SAE B

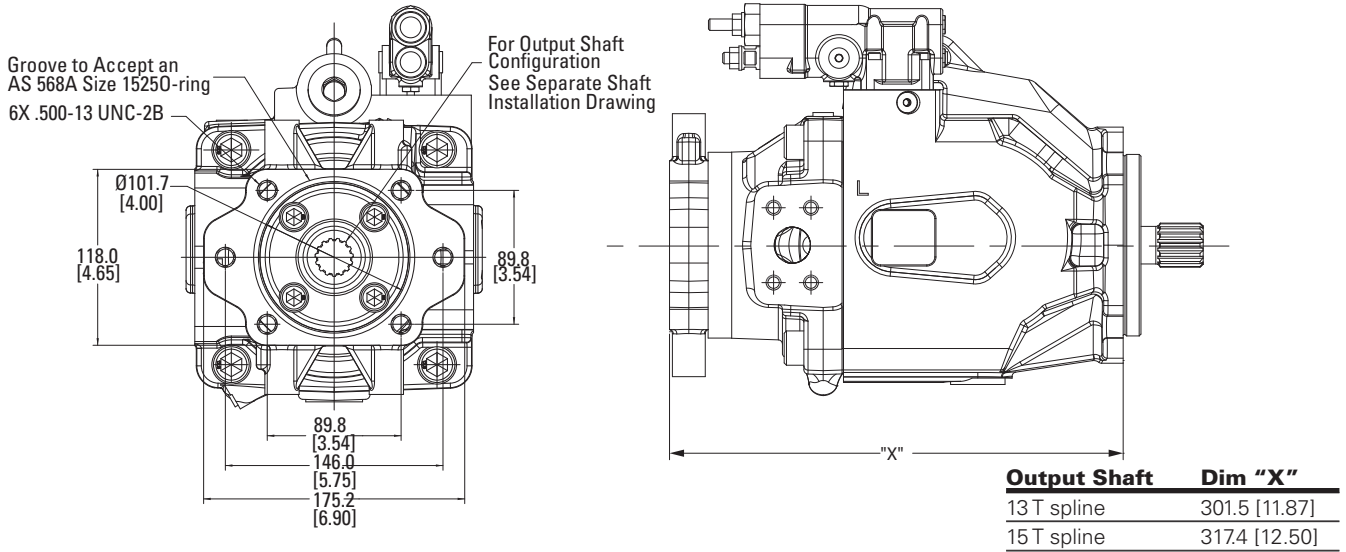

B-Thru-Drive Cover Plate Installation

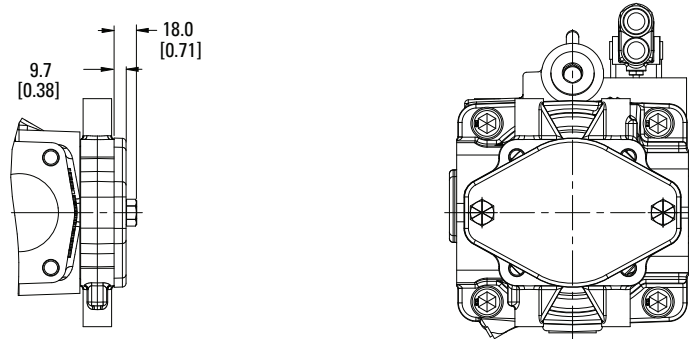

Output Shaft Installation 13T Spline

Maximum Torque
209 Nm [1850 in-lbf]

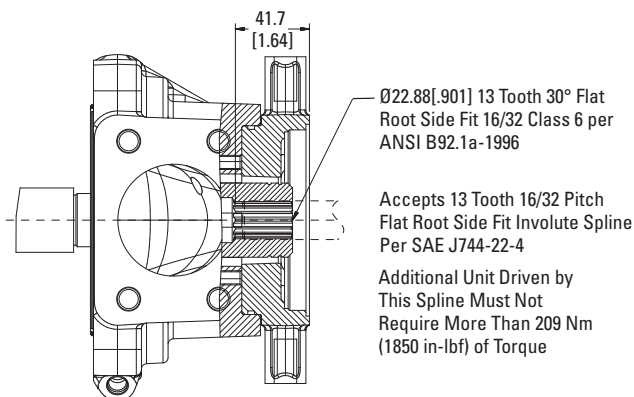

Output Shaft Installation 15T Spline

Maximum Torque
338 Nm [2987 in-lbf]

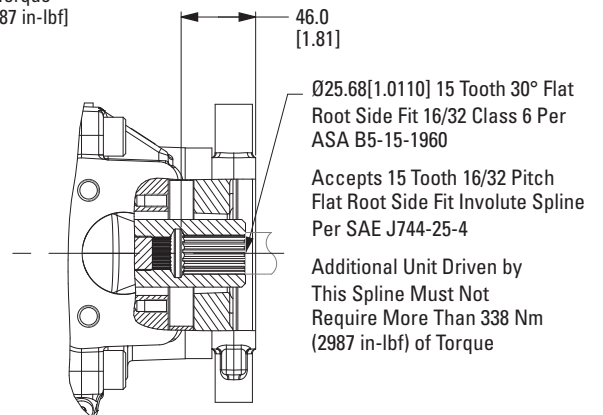

Pump Installation

ADY074 Thru-Drive SAE C

Thru-Drive SAE C

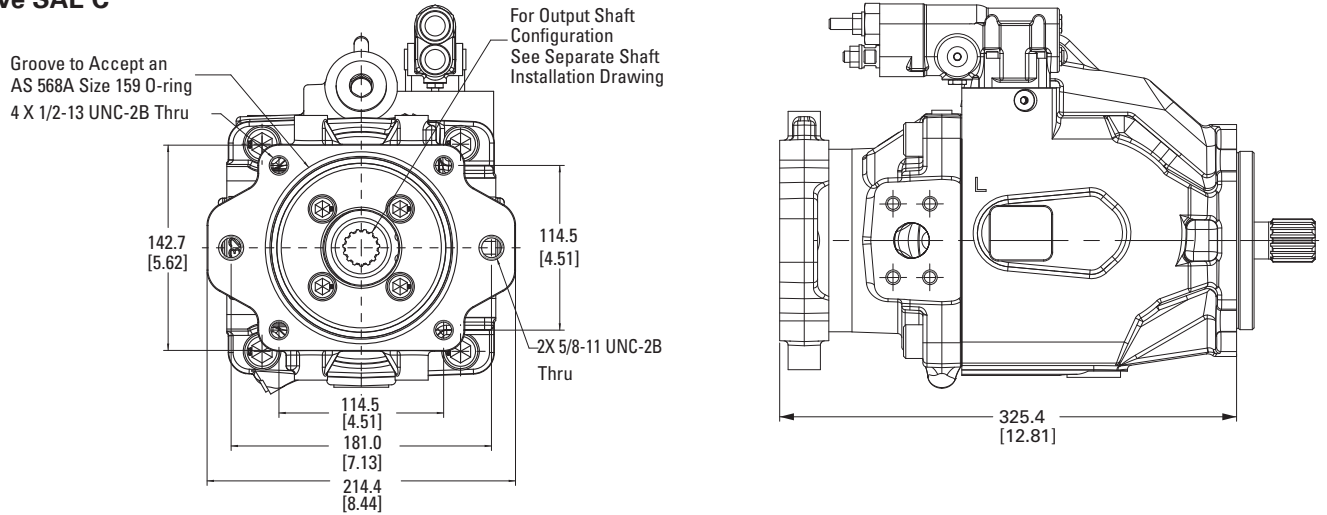

C-Thru-Drive Cover Plate Installation

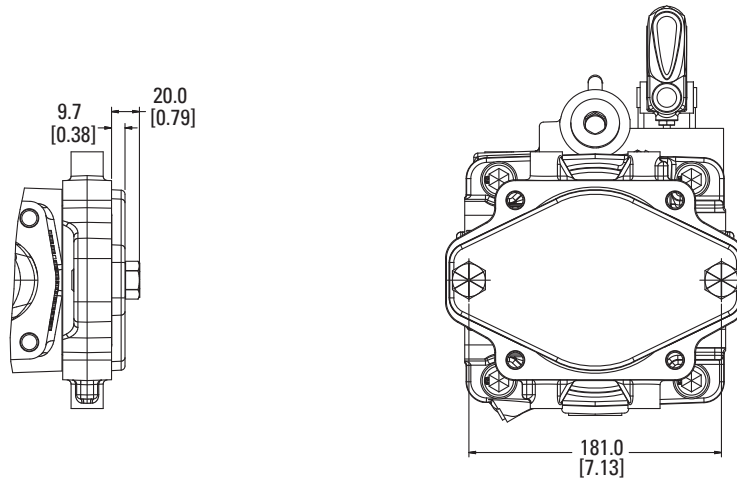

Output Shaft Installation 14T Spline

Maximum Torque
407 Nm [3600 in-lbf]

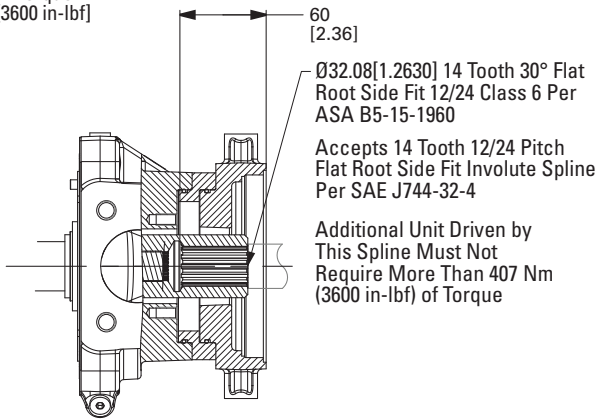

Pump Installation

ADY098 C-Mount / Side-Ported with Load Sense and Pressure Compensator Control

RH Rotation

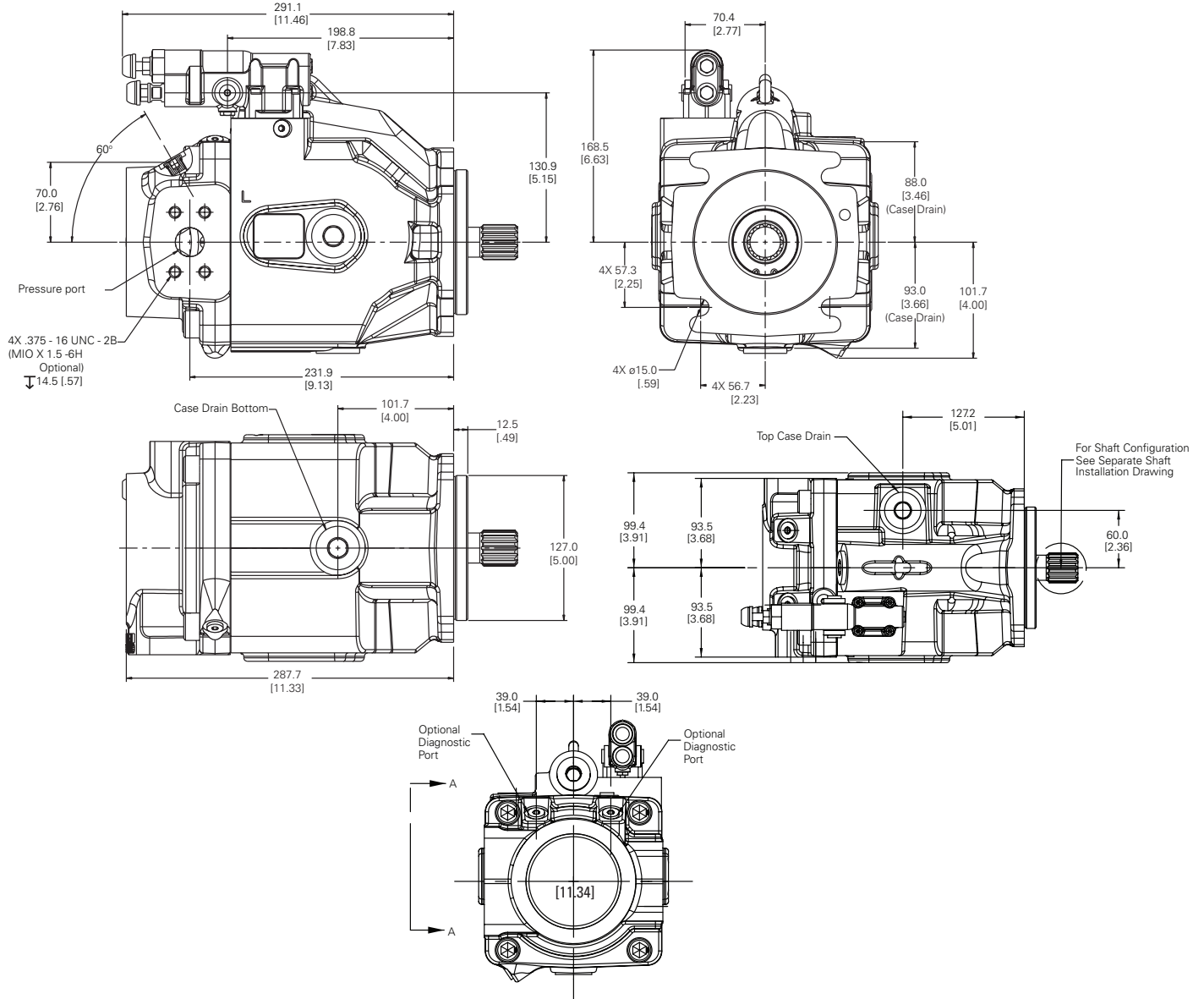

View A-A

LH Rotation

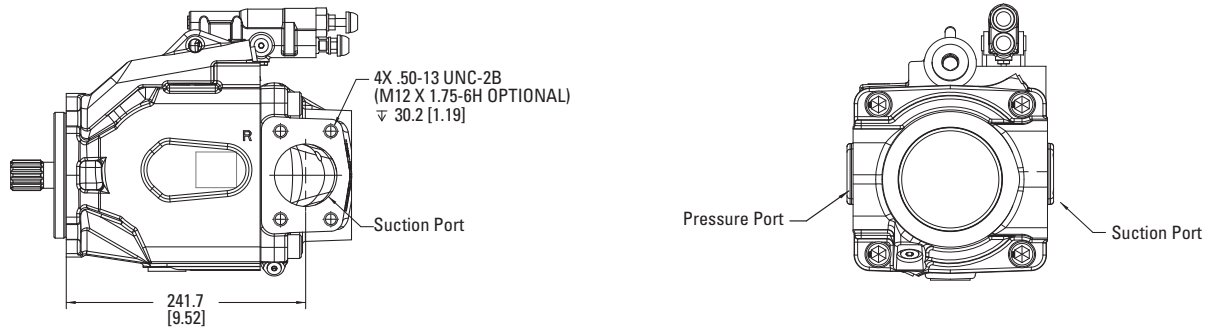

Pump Installation

ADY098 C-Mount /Rear-Ported with Load Sense and Pressure Compensator Control

RH Rotation

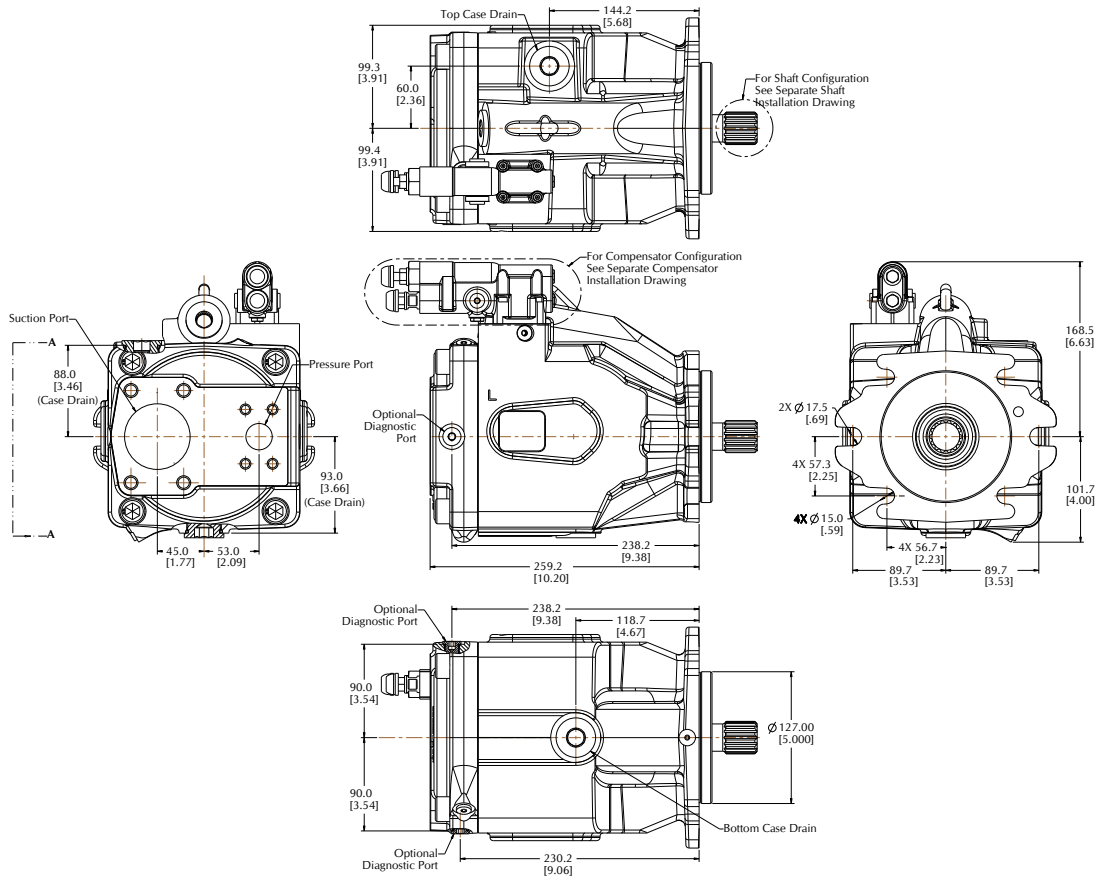

View A - A

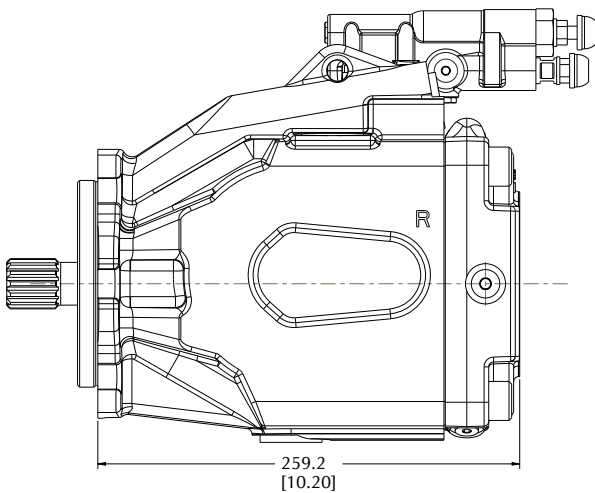

LH Rotation

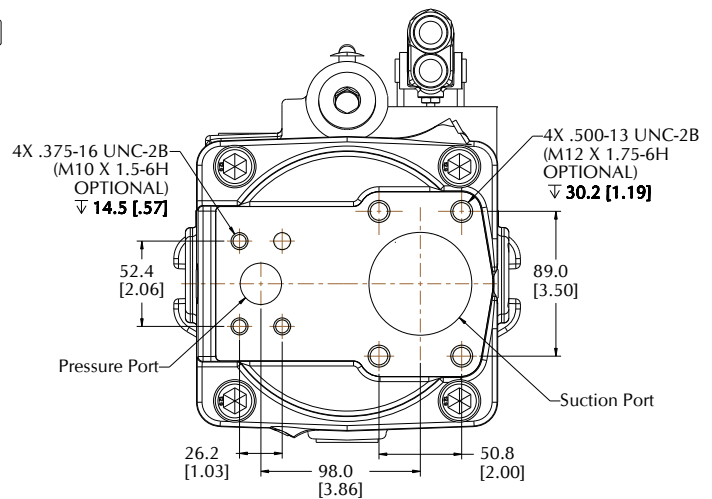

Pump Installation

ADY098 Thru-Drive SAE A

Thru-Drive SAE A

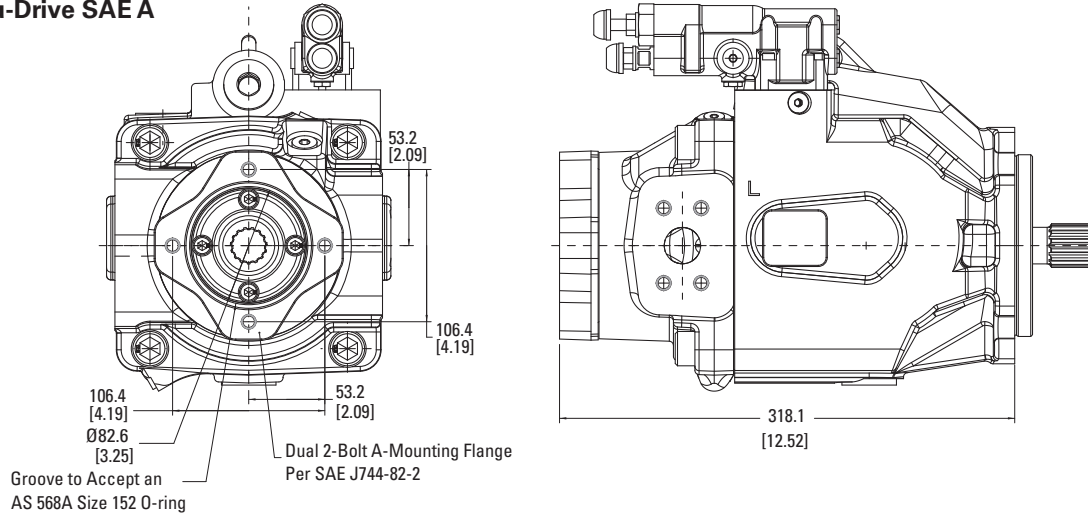

A Thru-Drive Cover Plate Installation

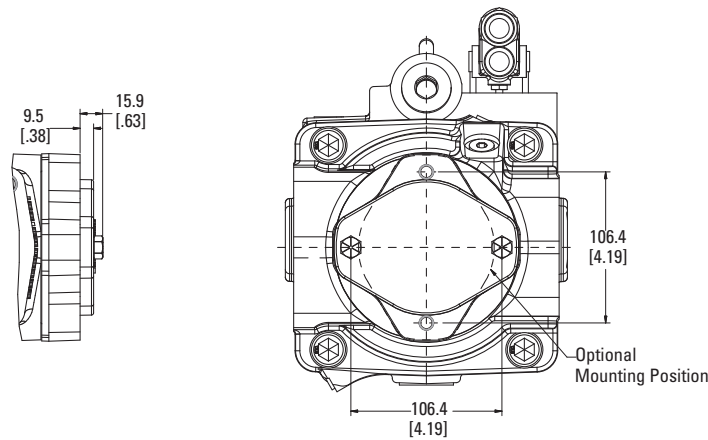

Output Shaft Installation 9T Spline

Maximum Torque
58 Nm [513 in-lbf]

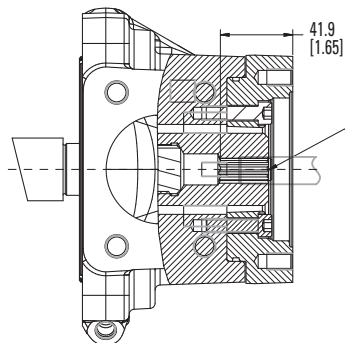

Additional Unit Driven by This Spline Must Not Require More Than 58 Nm (513 in-lbf) of Torque

Output Shaft Installation 11T Spline

Maximum Torque
124 Nm [1100 in-lbf]

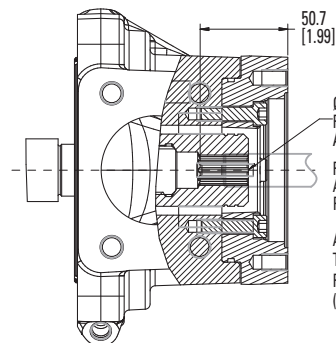

Additional Unit Driven by This Spline Must Not Require More Than 124 Nm (1100 in-lbf) of Torque

Pump Installation

ADY098 Thru-Drive SAE B

Thru-Drive SAE B

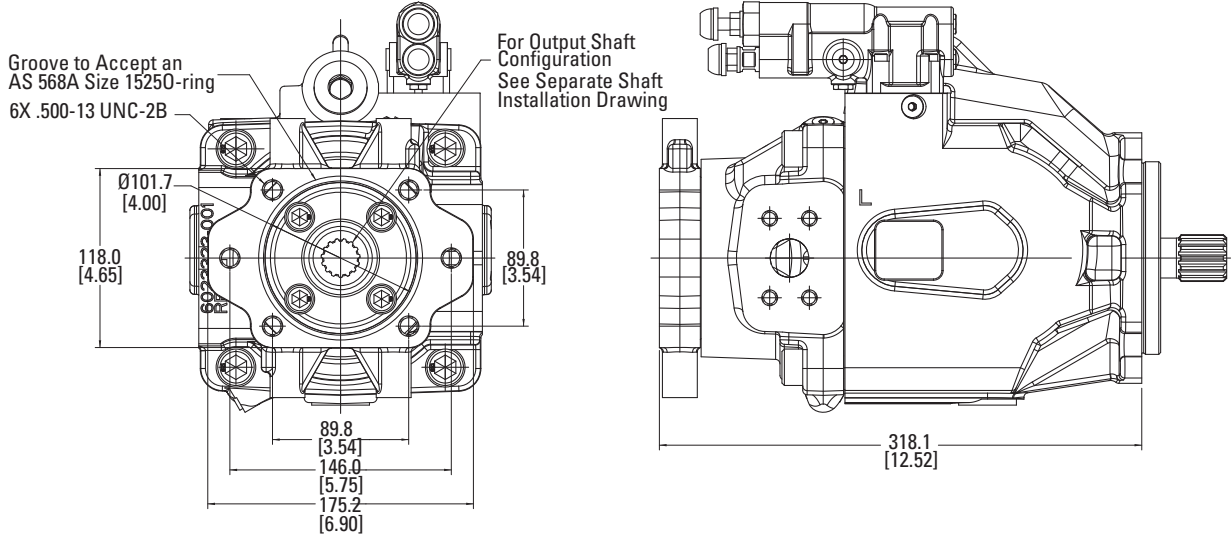

B-Thru-Drive Cover Plate Installation

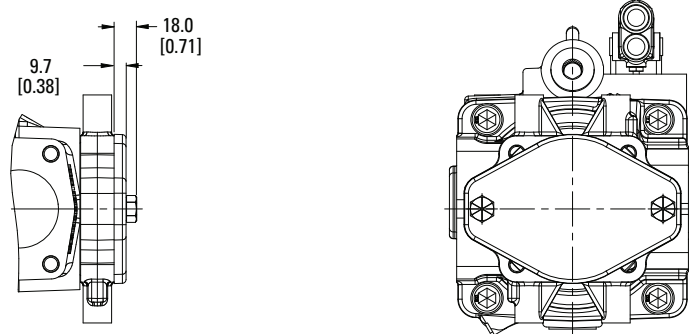

Output Shaft Installation 13T Spline

Maximum Torque
209 Nm [1850 in-lbf]

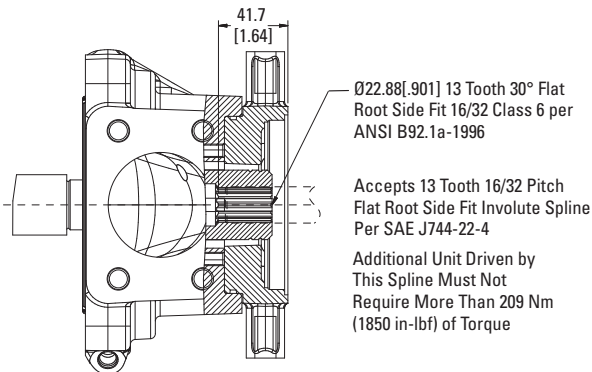

Output Shaft Installation 15T Spline

Maximum Torque
338 Nm [2987 in-lbf]

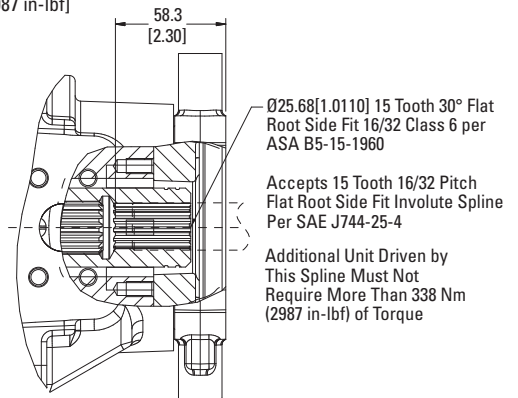

Pump Installation

ADY098 Thru-Drive SAE C

Thru-Drive SAE C

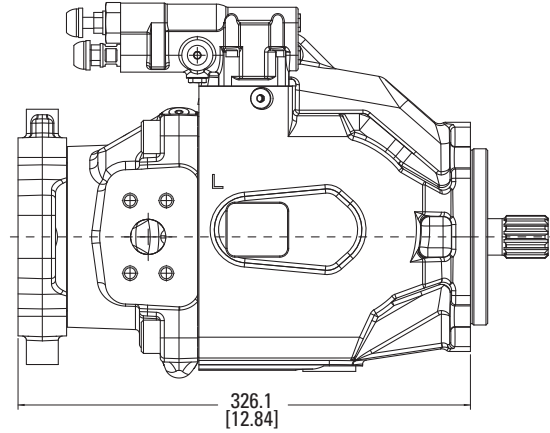
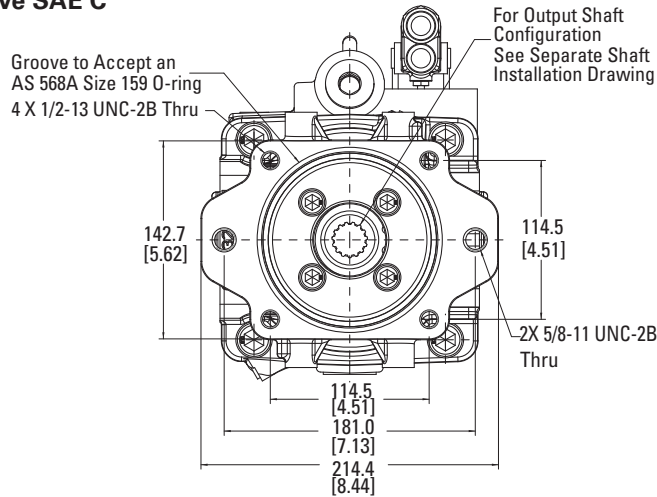

C-Thru-Drive Cover Plate Installation

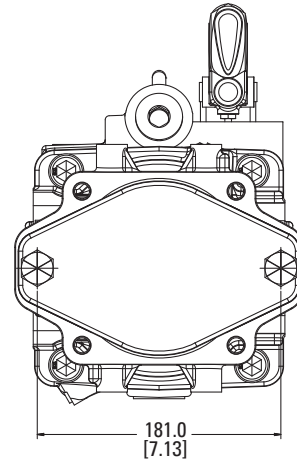
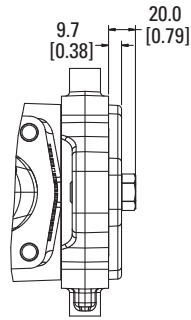

Output Shaft Installation 14T Spline

Maximum Torque
553 Nm [4890 in-lbf]

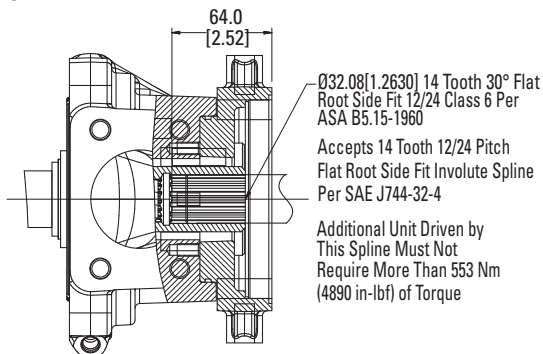

Output Shaft Installation 17T Spline

Maximum Torque
553 Nm [4890 in-lbf]

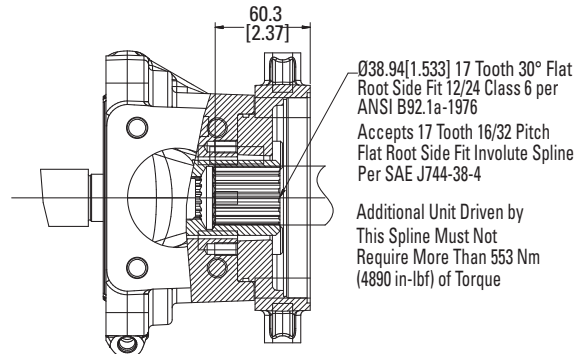

Control Installation

Pressure Compensator

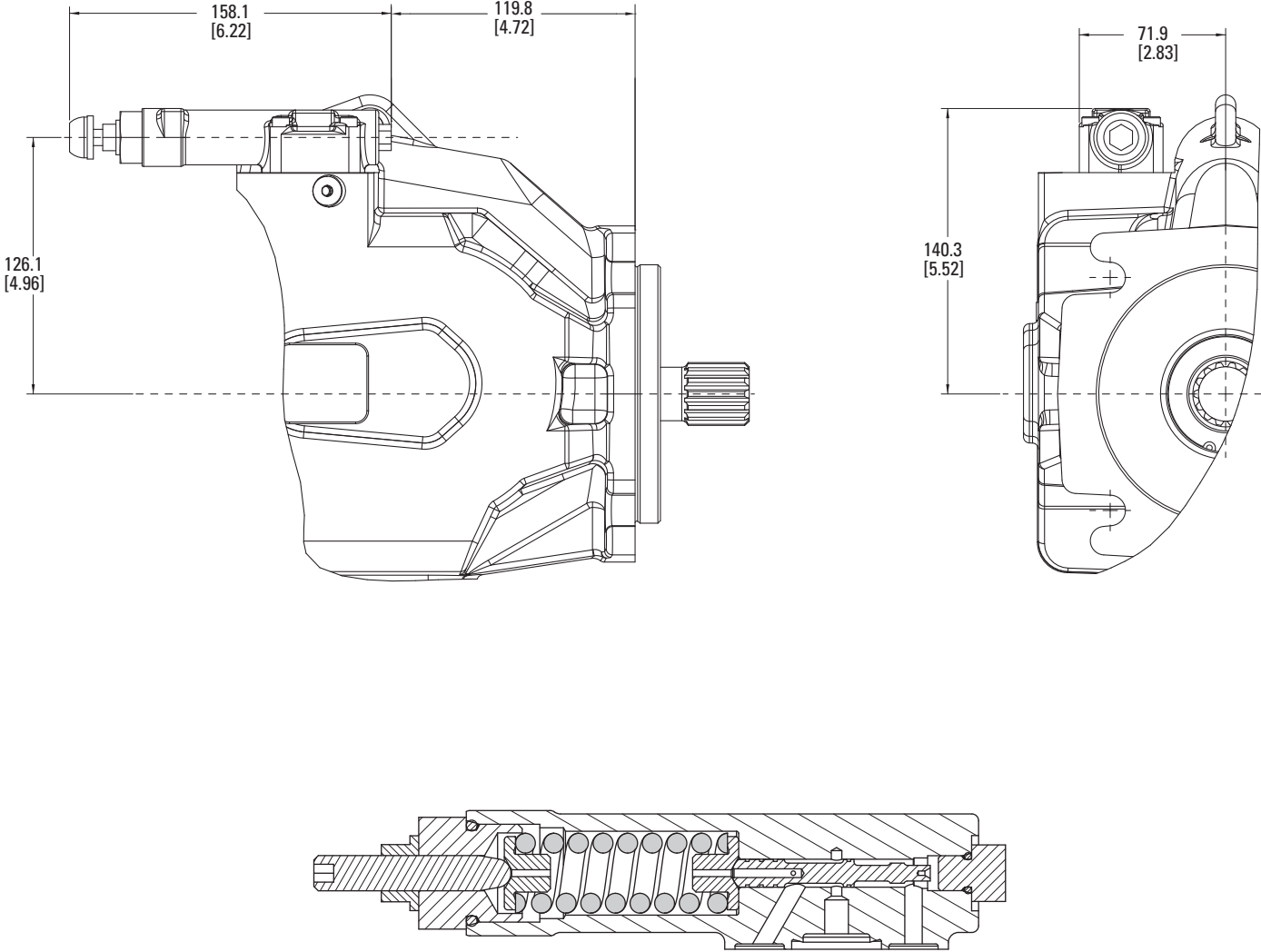

Control Installation

Load Sense and Pressure Compensator

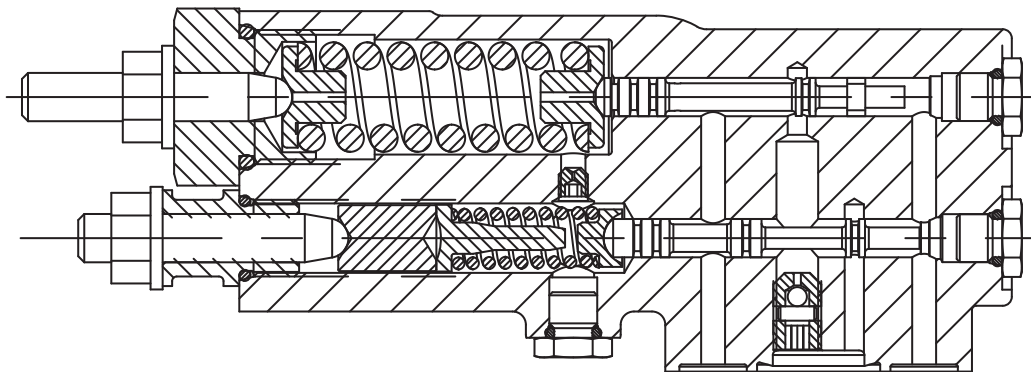
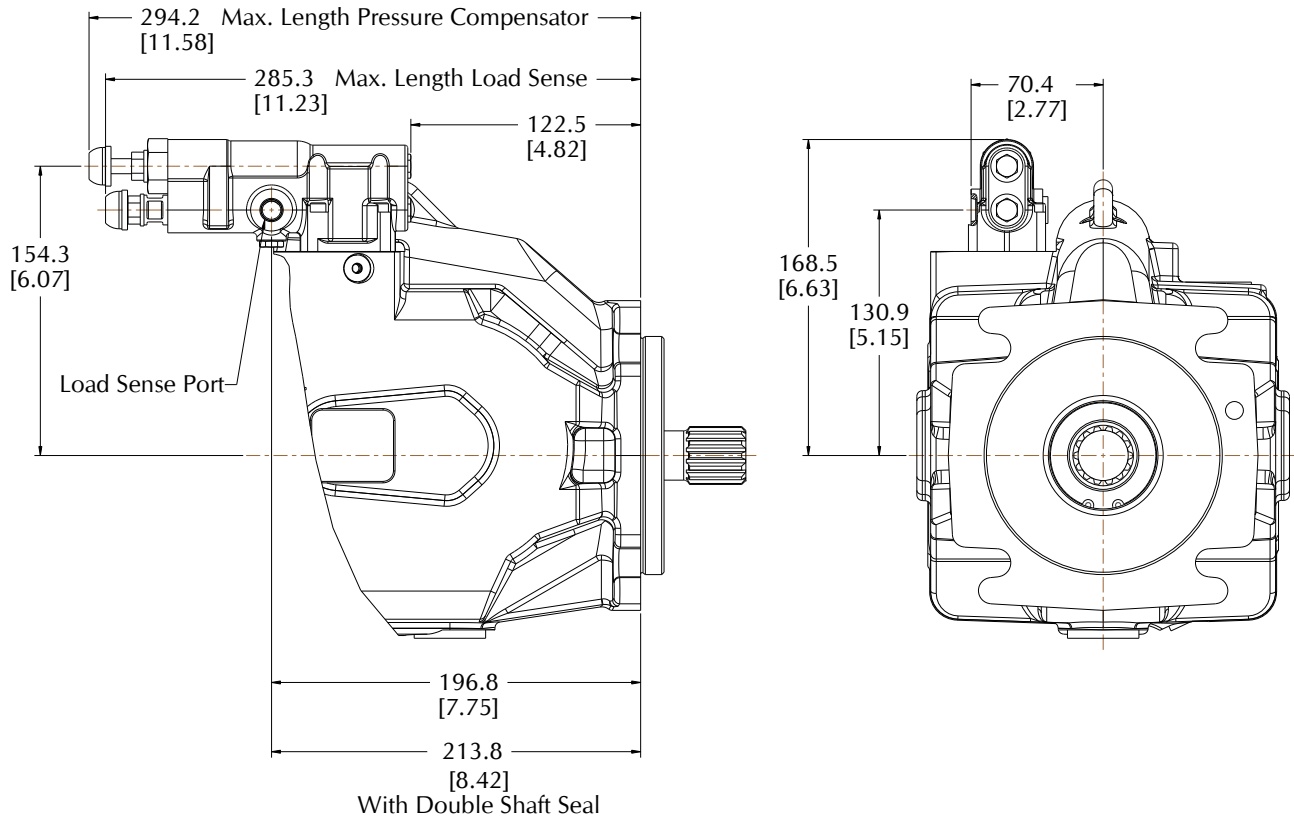

Control Installation

EH Inverse Proportional Pressure Control (IPPC)

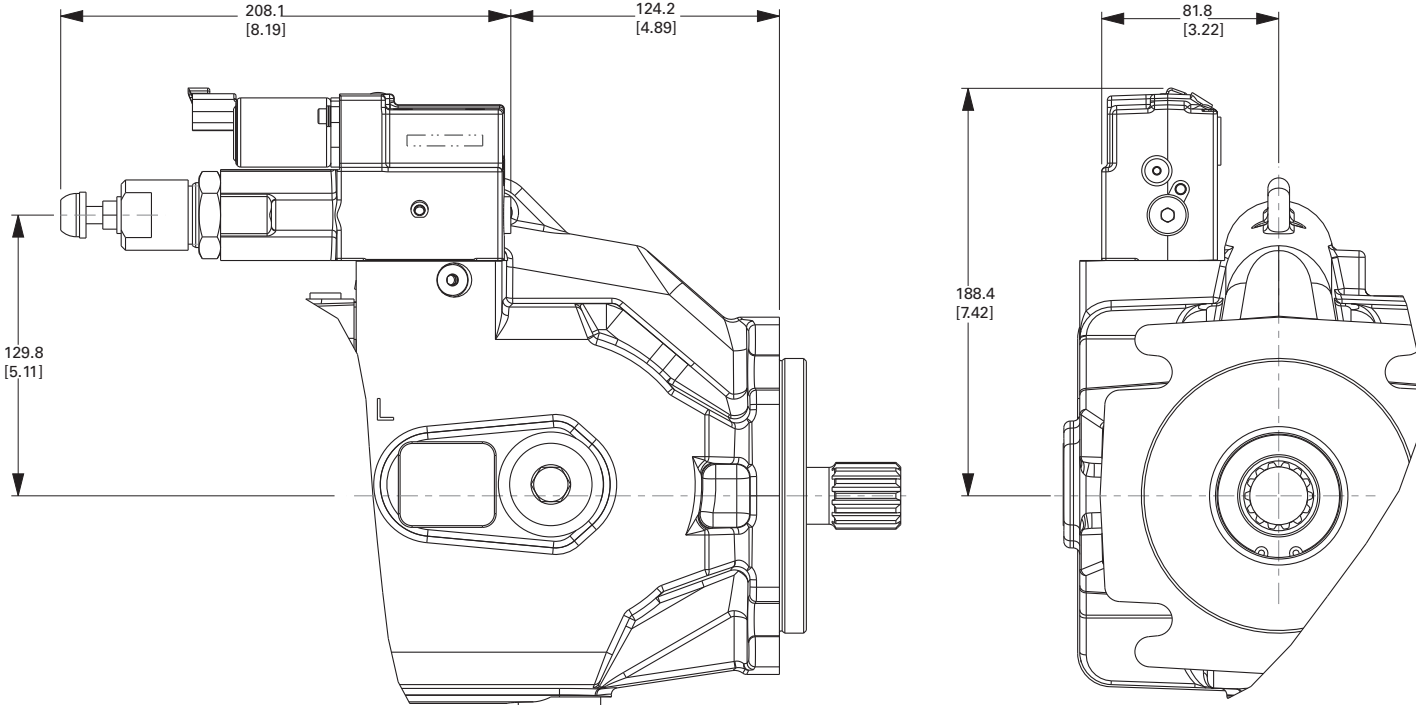

AMP CONNECTOR

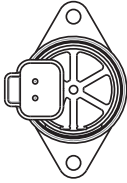

DEUTSCH CONNECTOR

Control Installation

Electronic Destroke Valve

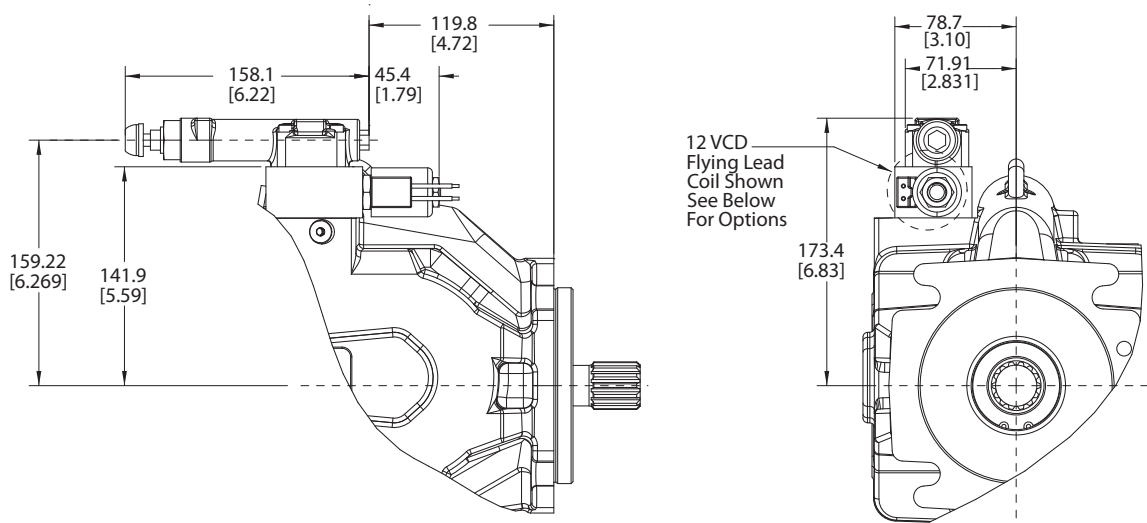
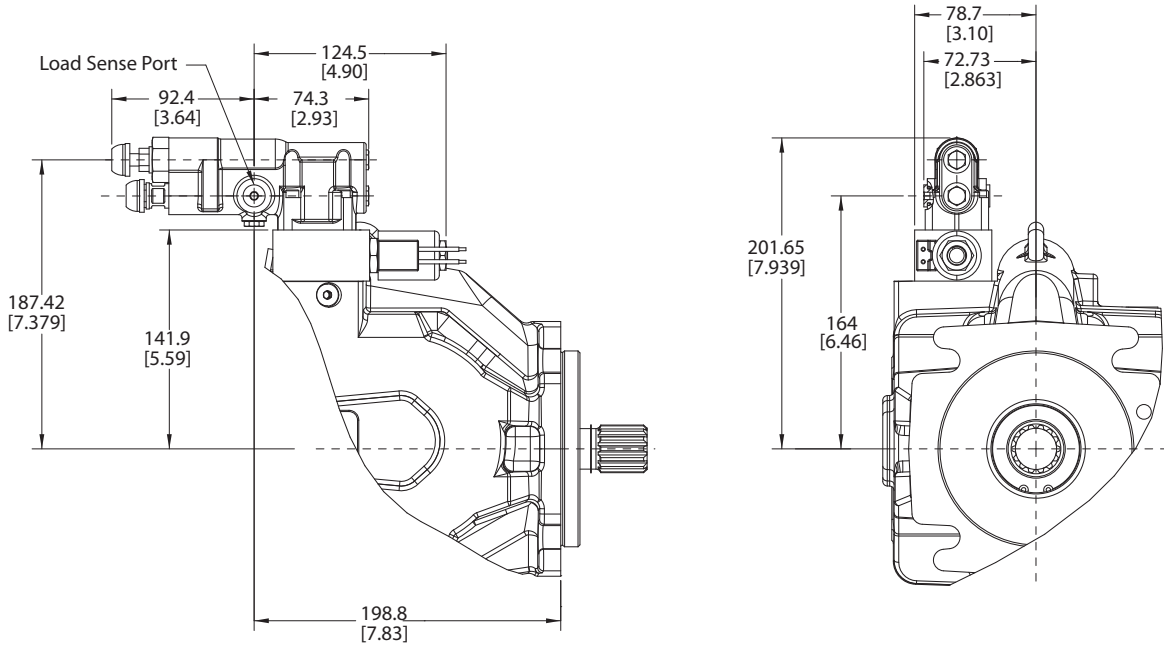

Optional Connectors

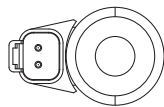

Deusch Option

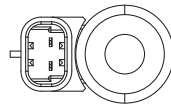

Metri-Pack 280 Option

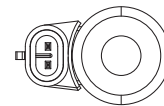

Metri-Pack 150 Option

External Manual Stroke Adjustment

Maximum Stroke Limiter

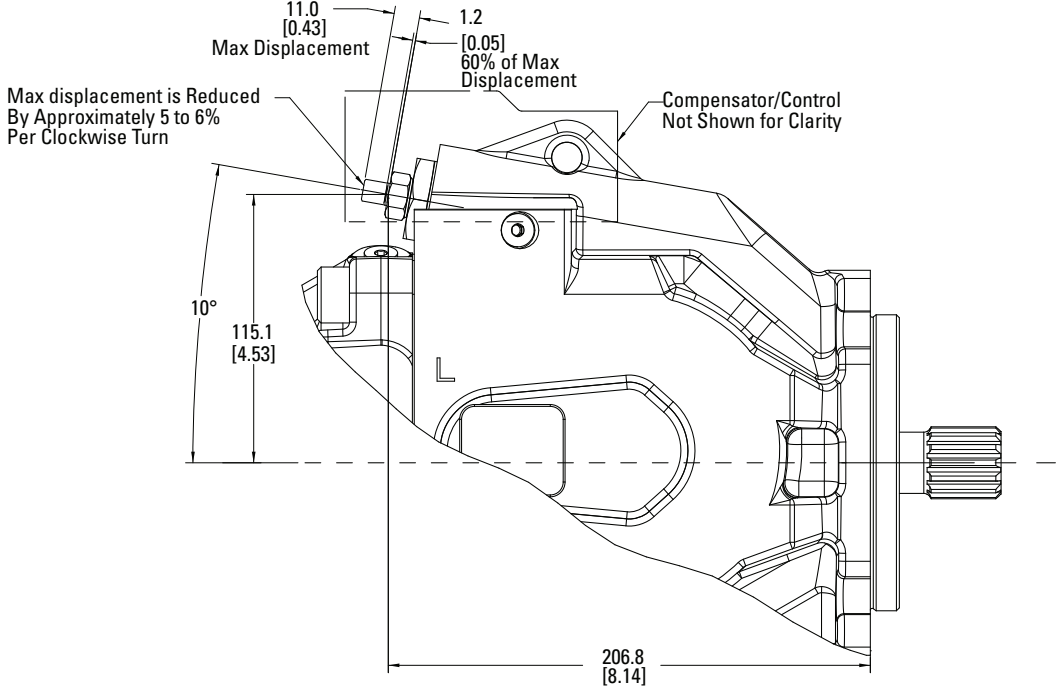

Input Shaft Options

05 Code

Maximum Torque
450 Nm [3980 in-lbf]

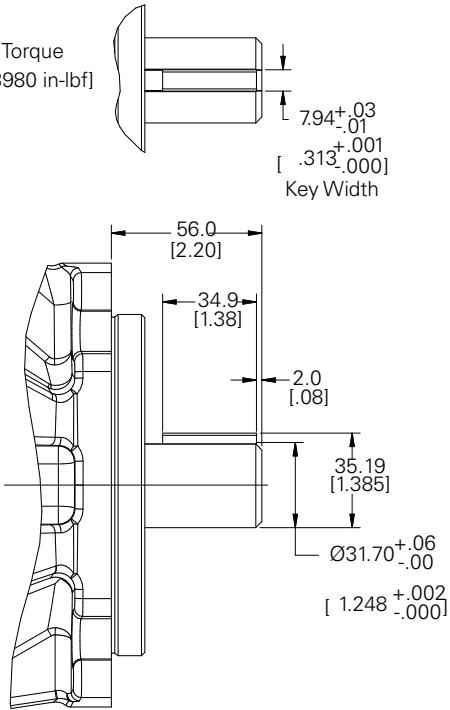

06 Code

Maximum Torque
640 Nm [5660 in-lbf]

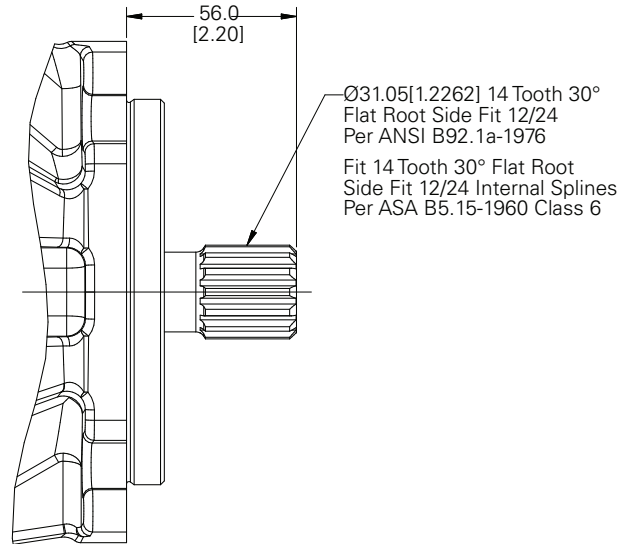

07 Code

Maximum Torque
765 Nm [6770 in-lbf]

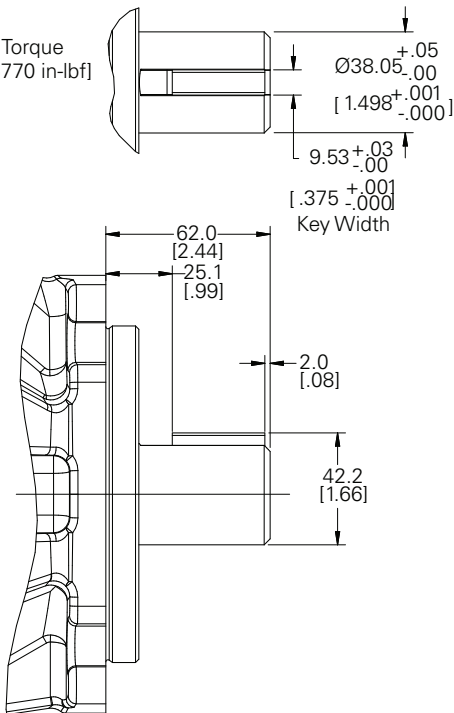

08 Code

Maximum Torque
765 Nm [6765 in-lbf]

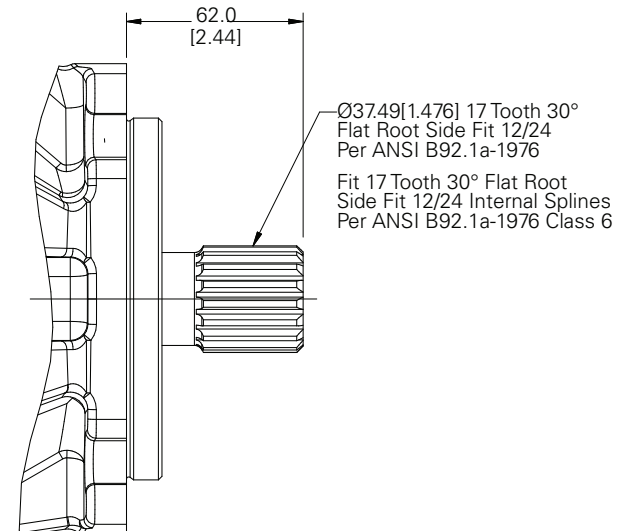

Input Shaft Options

10 Code

Maximum Torque

640 Nm [5660 in-lbf]

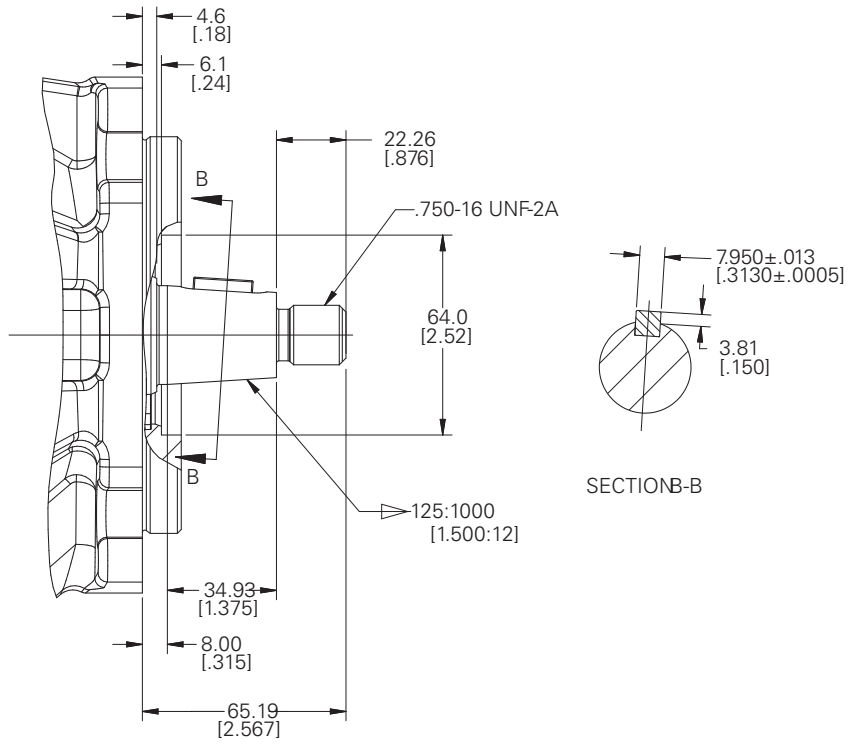

Center of Gravity

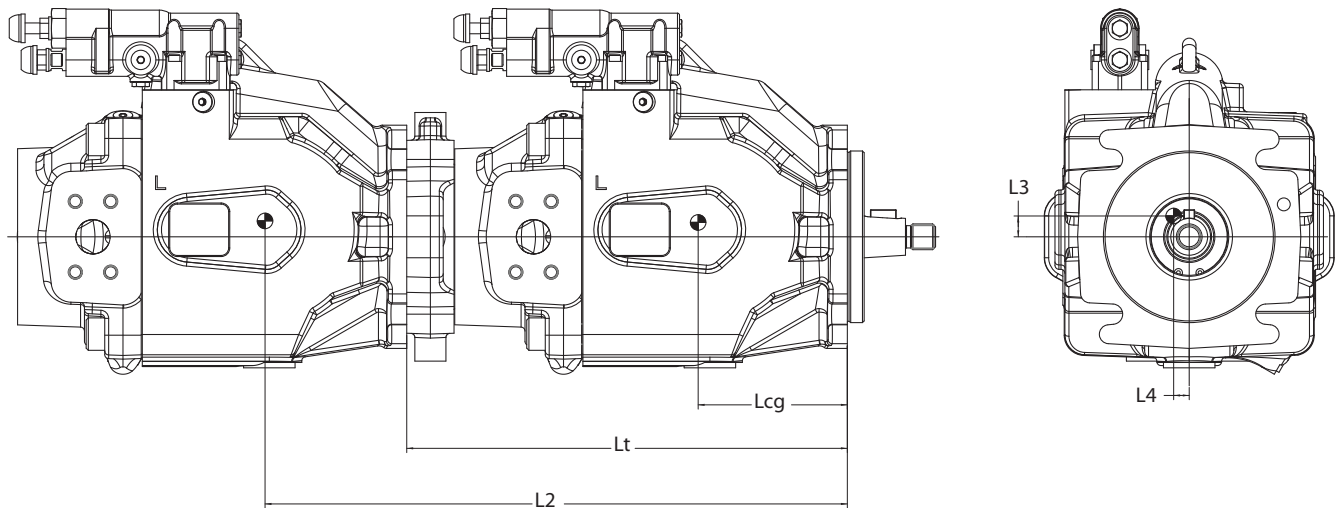

	Side Port			Thru-Drive SAE Pad			Length	
	Lcg	L3	L4	Lcg	L3	L4	Lt	
ADY074	138.5 (5.45)	8.0 (0.31)	2.3 (0.09)	A	140.8 (5.54)	8.5 (0.34)	2.2 (0.09)	301.5 (11.87)
				B (13T SPLINE)	144.1 (5.67)	8.3 (0.33)	2.2 (0.09)	301.5 (11.87)
				B (15T SPLINE)	147.9 (5.82)	7.6 (0.30)	2.1 (0.08)	317.4 (12.50)
				C	152.7 (6.01)	7.9 (0.31)	2.1 (0.08)	325.4 (12.81)
ADY098	139.7 (5.50)	8.4 (0.33)	3.2 (0.12)	A	145.8 (5.74)	7.9 (0.31)	2.8 (0.11)	318.1 (12.52)
				B	149.3 (5.88)	7.6 (0.30)	2.7 (0.11)	318.1 (12.52)
				C	153.8 (6.06)	7.5 (0.30)	2.6 (0.10)	326.1 (12.84)

Examples: Calculation L₂

Tandem ADY098 Thru-drive with ADY098 Side Ported

$$L_2 = L_t + L_{cg} \quad 318.1 \text{ mm} + 139.7 \text{ mm} = 457.8 \text{ mm (18.0 in)}$$

Tandem Pump Applications

Eaton recommends that tandem pump applications be provided with additional support to limit overhung loading of the mounting flange. The thru-drive alternate attachment points on the rear flange may be used with a customer designed support.

Installation and Start-up

Warning: Care should be taken that mechanical and hydraulic resonances are avoided in the application of the pump. Such resonances can seriously compromise the life and/or safe operation of the pump.

Drive Data

Mounting attitude should be horizontal using the appropriate case drain ports to ensure that the case remains full of fluid at all times. Consult your local Eaton Representative if a different arrangement is required.

Fluid Cleanliness

The 620 Series pumps are rated in anti-wear petroleum fluids with a contamination level of 21/18/13 per ISO 4406. Operation in fluids with levels more contaminated than this is not recommended. Fluids other than petroleum, severe service cycles, or temperature extremes are cause for adjustment of these codes. Please contact your Eaton Representative for specific duty cycle recommendation.

In those cases where geometric tolerances of mounting are critical, or where specific tolerance ranges are required and not specified, consult Eaton Engineering for specific limits.

Direction of shaft rotation, viewed from the prime mover end, must be as indicated in the model designation on the pump – either right hand (clockwise) or left hand (counterclockwise).

Direct coaxial drive through a flexible coupling is recommended. If drives imposing radial shaft loads are considered, please consult your Eaton Representative.

Eaton 620 Series pumps, as with any variable displacement piston pumps, will operate with apparent satisfaction in fluids up to the rating specified here. Experience has shown however, that pump and hydraulic system life is not optimized with high fluid contamination levels (high ISO cleanliness codes).

Proper fluid condition is essential for long and satisfactory life of hydraulic components and systems. Hydraulic fluid must have the

Start-up Procedure

Make sure the reservoir and circuit are clean and free of dirt/debris prior to filling with hydraulic fluid.

Fill the reservoir with filtered oil and fill to a level sufficient enough to prevent vortexing at the suction connection to pump inlet. It is good practice to clean the system by flushing and filtering, using an external slave pump.

Caution: Before the pump is started, fill the case through the uppermost drain port with hydraulic fluid of the type to be used. The case drain line must be connected directly to the reservoir and must terminate below the oil level.

correct balance of cleanliness, materials, and additives for protection against wear of components, elevated viscosity and inclusion of air.

Essential information on the correct methods for treating hydraulic fluid is included in Eaton publication 561 – “Eaton Guide to Systemic Contamination Control” – available from your local Eaton distributor. In this publication, filtration and cleanliness levels for extending the life of axial piston pumps and

Once the pump is started, it should prime within a few seconds. If the pump does not prime, check to make sure that there are no restrictions between the reservoir and the inlet to the pump, and that the pump is being rotated in the proper direction, and that there are no air leaks in the inlet line and connections. Also check to make sure that trapped air can escape at the pump outlet.

After the pump is primed, tighten the loose outlet connections, then operate for five to ten minutes (unloaded) to remove all trapped air from the circuit.

If the reservoir has a sight gage, make sure the fluid is clear – not milky.

other system components are listed. Included is an excellent discussion of the selection of products needed to control fluid condition.

Eaton
Hydraulics Group USA
14615 Lone Oak Road
Eden Prairie, MN 55344
USA
Tel: 952-937-9800
Fax: 952-294-7722
www.eaton.com/hydraulics

Eaton
Hydraulics Group Europe
Route de la Longeraie 7
1110 Morges
Switzerland
Tel: +41 (0) 21 811 4600
Fax: +41 (0) 21 811 4601

Eaton
Hydraulics Group Asia Pacific
Eaton Building
No.7 Lane 280 Linhong Road
Changning District, Shanghai
200335 China
Tel: (+86 21) 5200 0099
Fax: (+86 21) 2230 7240