

CETOP-07 MODULAR CHECK VALVE



Characteristics

TYPE	FLOW	PRESSURE	WEIGHT
IRM-07/P	200 l/min.	320 bar	5 Kg.
IRM-07/T	200 l/min.	320 bar	5 Kg.

Description Cetop-07 size modular mounting check valve.

Dimensions

Type IRM-07/P

Symbol

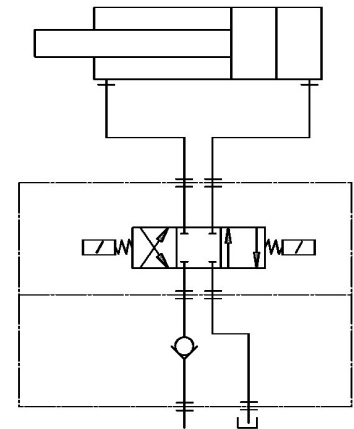
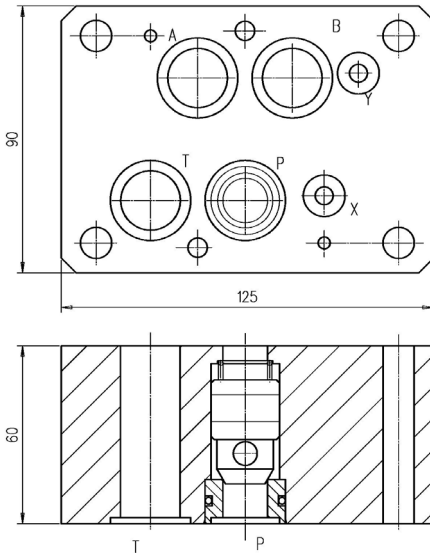

Dimensions

Type IRM-07/T

Symbol

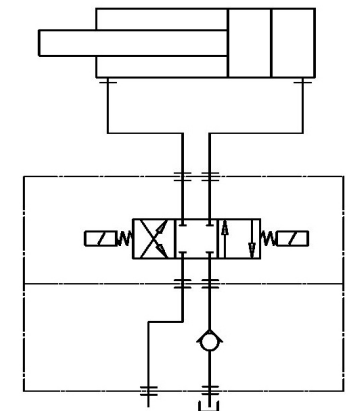
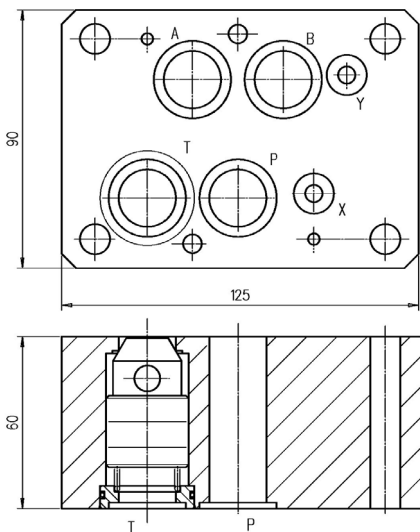

Ordering code

IRM-07 / *
 P=check on P port T=check on T port
 CETOP 07 size modular check valve

Installation rules

- The valves type IRM can be mounted in any position
- Fluid to be used: hydraulic oil in compliance with DIN 51524 rules, viscosity between 30 and 100 mm²/s (cSt) at 40°C
- Recommended filtration of 25µ
- Hydraulic fluid temperature: from -20° to +75°C