

# CETOP-03 SIZE PRESSURE RELIEF VALVE



## Characteristics

TYPE	PRESSURE	MAX FLOW (l/min.)
VMM-03*/100/*	30-100 bar	35
VMM-03*/210/*	50-210 bar	
VMM-03*/350/*	100-350 bar	

## Description

Direct acted CETOP-03 size modular pressure relief valve. Pressure adjustment is achieved by loosening the locking nut and turning the cartridge screw. ( clockwise it increases ). Upon request, it is supplied with adjustment handwheel.

## Dimensions

## Symbol

VMM-03/P

Weight 1.4 Kg

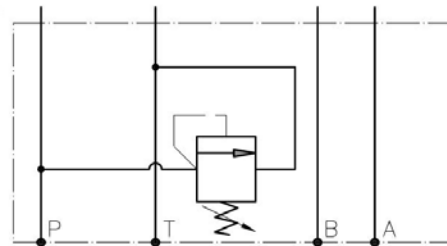
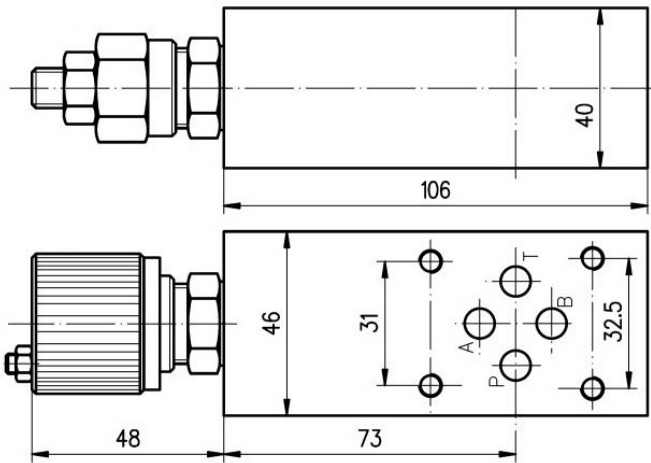

VMM-03/A

Weight 1.4 Kg

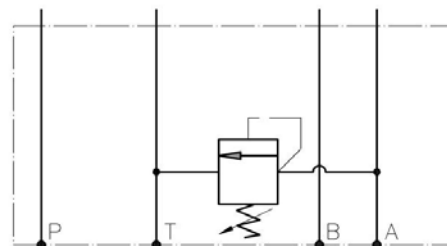
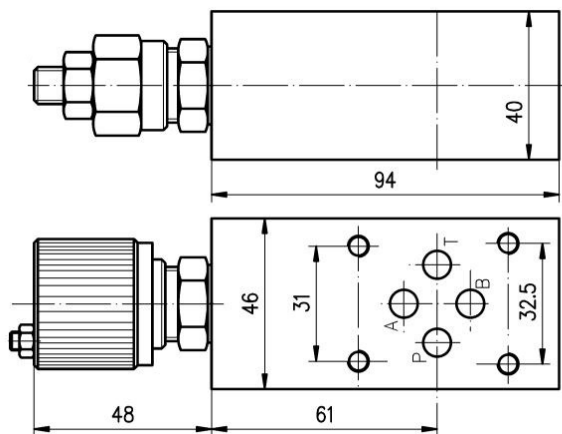

# CETOP-03 SIZE PRESSURE RELIEF VALVE



**VMM-03/B**

**Weight 1.4 Kg**

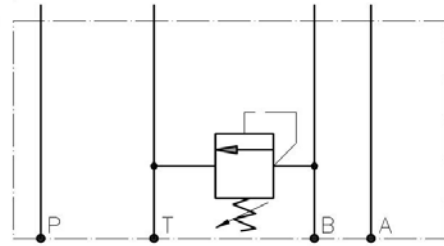
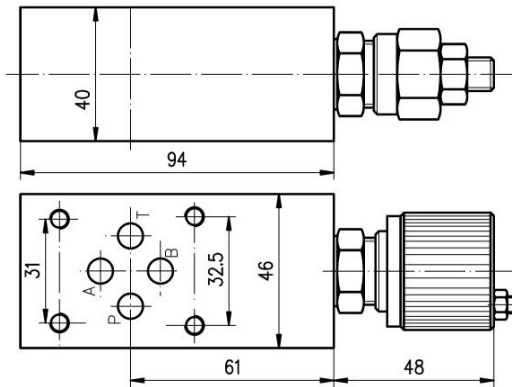

**VMM-03/AB**

**Weight 1.6 Kg**

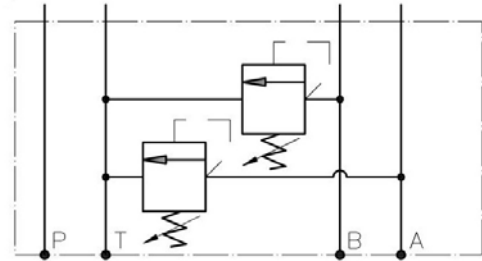
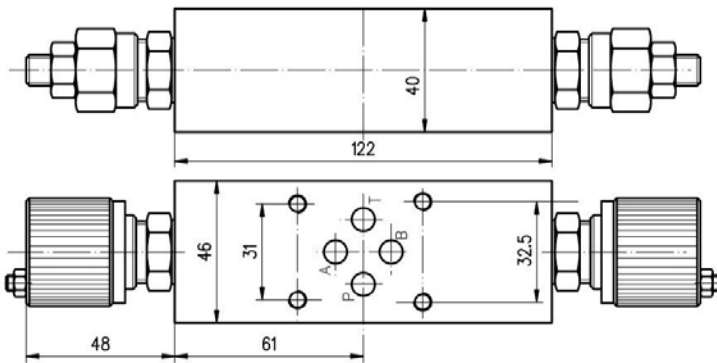

## Installation rules

## Seals

N°4 OR-108

- VMM valves can be mounted in any position.
- Fluid to be used: mineral oil, or fluid having the same characteristics, (viscosity between 2.8 and 380 cSt )  
The use of mineral oils is recommended (H-LP according DIN-51524 part2)
- Recommended filtration: 25 $\mu$
- Hydraulic fluid temperature: -20° e +75°C

## Ordering code

