

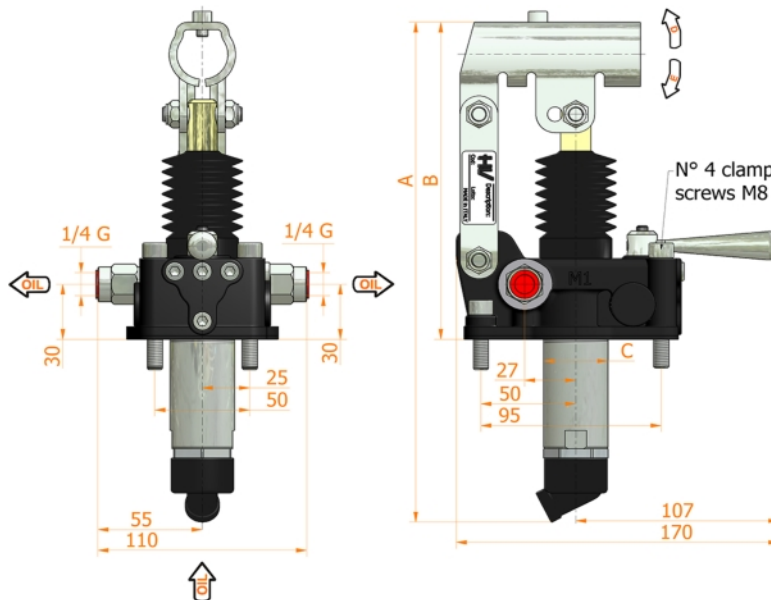

PMDVB 6-12-25-45 ca-byA-s

with 4/3 diverter opened centre
with dual pilot check valve
with brakes - with pressure relief valve
double acting hand pump for a double acting cylinder
for fixing to tank

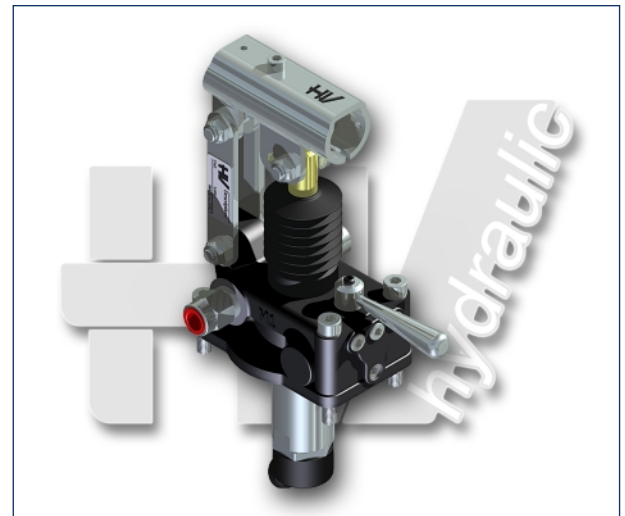
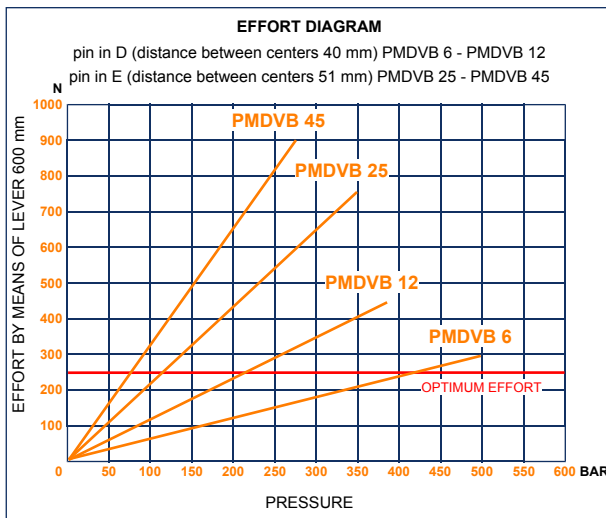
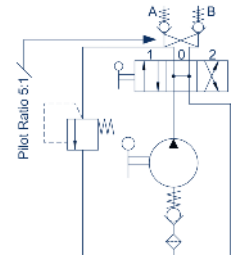

Specifications:

- Cast iron body
- Piston treated with Niploy
- White zinc plated support lever
- Lever connection Ø 27
- White zinc plated external parts
- Standard colour black
- Oil tank mounting kit included
- With hydraulic brakes to operate under 50 bar pressure
- Pressure relief valve standard setting: 100 bar

| DISPLACEMENT cm ³ | A mm | B mm | C mm | D ° | E ° | ACTUAL DISPLACEMENT cm ³ | PRESSURE BAR | | MASS KG | CODE WITHOUT BELLOWS | CODE WITH BELLOWS |
|---------------------------------|---------|---------|---------|--------|--------|---|--------------|-----|------------|----------------------------|-------------------------|
| | | | | | | | OPTIMAL | MAX | | | |
| 6 | 253 | 166 | 34 | 26 | 31 | 6,970 | 420 | 500 | 3,400 | 6059.0306 | 6059.0307 |
| 12 | 253 | 166 | 34 | 26 | 31 | 12,095 | 220 | 380 | 3,400 | 6060.0306 | 6060.0307 |
| 25 | 273 | 172 | 34 | 30 | 30 | 25,280 | 120 | 350 | 3,450 | 6061.0306 | 6061.0307 |
| 45 | 283 | 172 | 40 | 45 | 33 | 44,532 | 80 | 280 | 3,500 | 6062.0306 | 6062.0307 |