

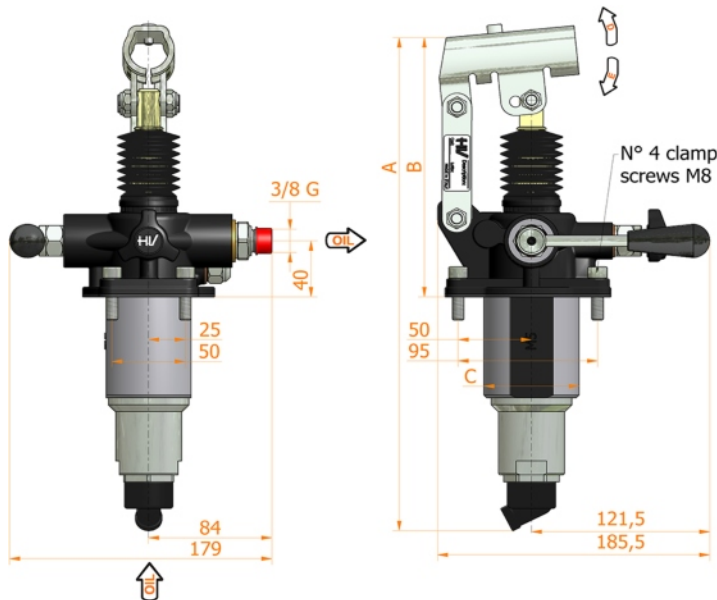

## PM2V 5/80 Lm-byB-s

with release hand knob  
 with exclusion lever for the 1st speed  
 with pressure relief valve  
 two speed hand pump for a single acting cylinder  
 for fixing to tank

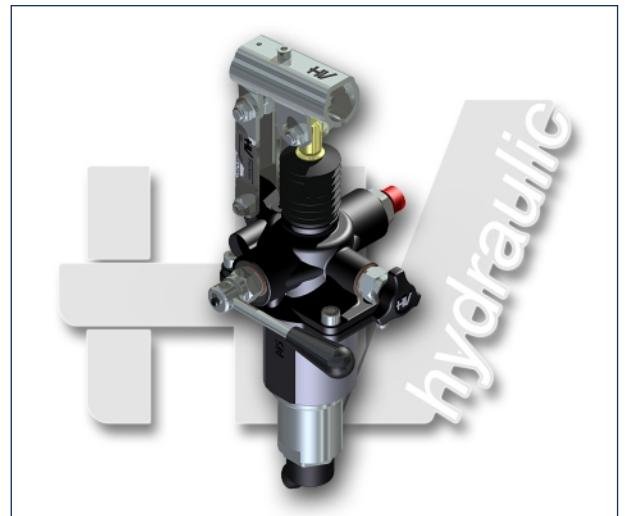
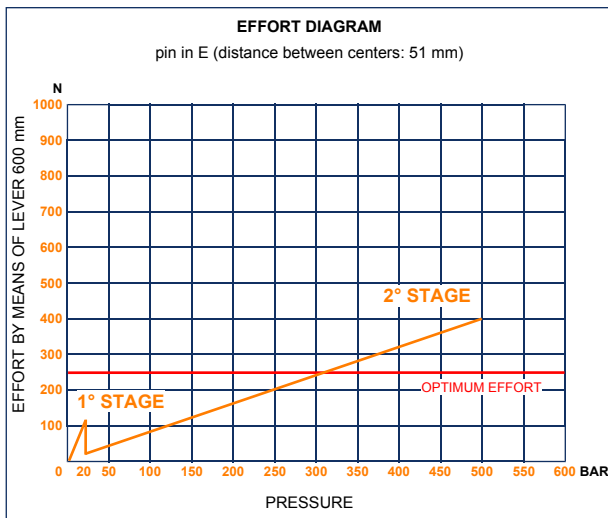
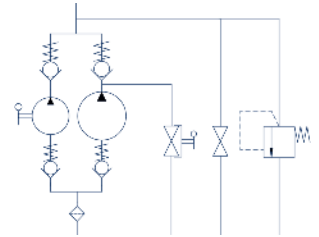

### Specifications:

- Cast iron body
- Piston treated with Niploy
- White zinc plated support lever
- Lever connection Ø 27
- White zinc plated external parts
- Standard colour black
- Oil tank mounting kit included
- Pressure relief valve standard setting: 400 bar

| DISPLACEMENT<br>cm <sup>3</sup> | A<br>mm | B<br>mm | C<br>mm | D<br>° | E<br>° | DISPLACEMENT cm <sup>3</sup> |         | PRESSURE BAR |         | MASS<br>KG | CODE<br>WITHOUT<br>BELLOWS | CODE<br>WITH<br>BELLOWS |
|---------------------------------|---------|---------|---------|--------|--------|------------------------------|---------|--------------|---------|------------|----------------------------|-------------------------|
|                                 |         |         |         |        |        | STAGE 1                      | STAGE 2 | STAGE 1      | STAGE 2 |            |                            |                         |
| 5-80                            | 354     | 185     | 65      | 30     | 32     | 80,588                       | 5,036   | 20           | 500     | 6,200      | 6071.0101                  | 6071.0128               |
|                                 |         |         |         |        |        |                              |         |              |         |            |                            |                         |
|                                 |         |         |         |        |        |                              |         |              |         |            |                            |                         |
|                                 |         |         |         |        |        |                              |         |              |         |            |                            |                         |
|                                 |         |         |         |        |        |                              |         |              |         |            |                            |                         |