

# intermediate pump - series XV

X11-1

STANDARD INTERMEDIATE PUMP  
FEMALE Ø25,4 FLANGE

**X 1 I 25 72 S I I A**

Series	X	series XV
Group	1	group 1
Category	I	intermediate pump
Displacement	25	3.8
Flange	72	Ø25.4 female right rotation 1P+1P
Shaft	S	SCI01 - Intermediate
Body	IN	I inlet - Ø30 Ø12 M6
	OUT	I outlet - Ø30 Ø12 M6
Cover	A	Ø25,5 female cover for left multiple pump element

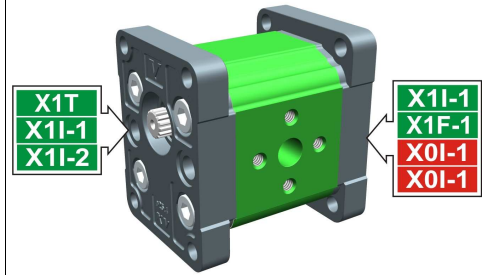

XI101

Technical data table

TYPE	Displacement cm3/rev	Max. Pressure		CODE																	
		P1 bar	P3 bar	Left rotation			Right rotation														
X11-1/0.9	0,91	240	280	X	1	I	16	71	S	I	I	A	X	1	I	16	72	S	I	I	A
X11-1/1.2	1,17	250	290	X	1	I	17	71	S	I	I	A	X	1	I	17	72	S	I	I	A
X11-1/1.7	1,56	250	290	X	1	I	18	71	S	I	I	A	X	1	I	18	72	S	I	I	A
X11-1/2.2	2,08	250	290	X	1	I	20	71	S	I	I	A	X	1	I	20	72	S	I	I	A
X11-1/2.6	2,60	250	300	X	1	I	21	71	S	I	I	A	X	1	I	21	72	S	I	I	A
X11-1/3.2	3,12	250	300	X	1	I	23	71	S	I	I	A	X	1	I	23	72	S	I	I	A
X11-1/3.8	3,64	250	300	X	1	I	25	71	S	I	I	A	X	1	I	25	72	S	I	I	A
X11-1/4.3	4,16	250	300	X	1	I	27	71	S	I	I	A	X	1	I	27	72	S	I	I	A
X11-1/4.9	4,94	250	300	X	1	I	29	71	S	I	I	A	X	1	I	29	72	S	I	I	A
X11-1/5.9	5,85	250	300	X	1	I	31	71	S	I	I	A	X	1	I	31	72	S	I	I	A
X11-1/6.5	6,50	250	300	X	1	I	32	71	S	I	I	A	X	1	I	32	72	S	I	I	A
X11-1/7.8	7,54	220	260	X	1	I	34	71	S	I	I	A	X	1	I	34	72	S	I	I	A
X11-1/9.8	9,88	190	230	X	1	I	36	71	S	I	I	A	X	1	I	36	72	S	I	I	A

P1) Max. working pressure - P3) Max. peak pressure

For heavy-duty applications, it is recommended to check the admissible torque of the shaft

Dimensions table

TYPE	Weight kg	A	B	D	E	F	D	E	F
		mm	mm	IN			OUT		
X11-1/0.9	0,950	74,5	37,3	Ø12	30	M6x1	Ø12	30	M6x1
X11-1/1.2	0,970	75,5	37,8	Ø12	30	M6x1	Ø12	30	M6x1
X11-1/1.7	1,010	77,0	38,5	Ø12	30	M6x1	Ø12	30	M6x1
X11-1/2.2	1,030	79,0	39,5	Ø12	30	M6x1	Ø12	30	M6x1
X11-1/2.6	1,060	81,0	40,5	Ø12	30	M6x1	Ø12	30	M6x1
X11-1/3.2	1,090	83,0	41,5	Ø12	30	M6x1	Ø12	30	M6x1
X11-1/3.8	1,120	85,0	42,5	Ø12	30	M6x1	Ø12	30	M6x1
X11-1/4.3	1,170	87,0	43,5	Ø12	30	M6x1	Ø12	30	M6x1
X11-1/4.9	1,200	90,0	45,0	Ø12	30	M6x1	Ø12	30	M6x1
X11-1/5.9	1,260	93,5	46,8	Ø12	30	M6x1	Ø12	30	M6x1
X11-1/6.5	1,300	96,0	48,0	Ø12	30	M6x1	Ø12	30	M6x1
X11-1/7.8	1,360	100,0	50,0	Ø12	30	M6x1	Ø12	30	M6x1
X11-1/9.8	1,500	109,0	54,5	Ø12	30	M6x1	Ø12	30	M6x1

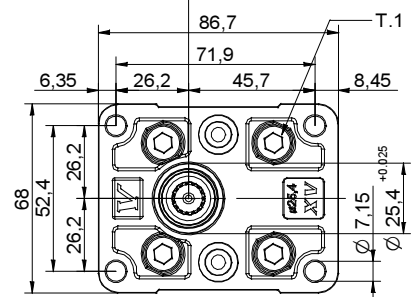
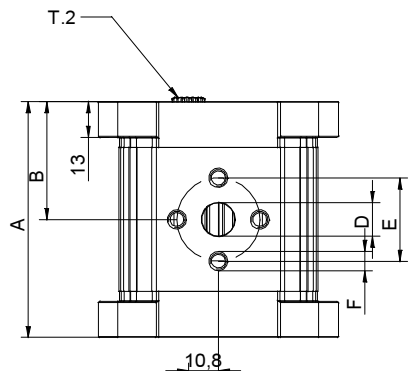
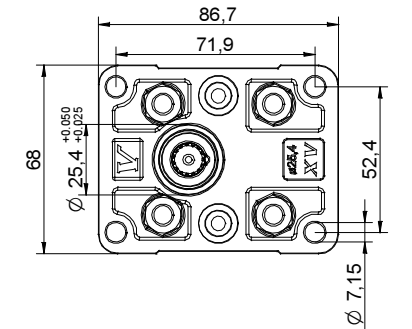

0104/08 XI12572SIIA.dft

T.1 = 24.5÷29.4 [Nm] - screw tightening torque M8

T.2 = 42.8 [Nm] - admissible shaft torque (N.B. When choosing a shaft, always check the admissible torque).

# Table of variations

**X11-1**

## Standard female $\varnothing 25,4$ FLANGE

Standard female $\varnothing 25,4$ FLANGE				Shaft		Cover		
Left rotation		Right rotation				Left rotation	Right rotation	
	<b>71</b>		<b>72</b>	SCI01 - Splined $T.2 = 42.8$ [Nm] $m=0,75$ $Z=15$ 				<b>A</b>
								<b>D</b>

Displacement	
TYPE	CODE
X11-1/0.9	<b>16</b>
X11-1/1.2	<b>17</b>
X11-1/1.7	<b>18</b>
X11-1/2.2	<b>20</b>
X11-1/2.6	<b>21</b>
X11-1/3.2	<b>23</b>
X11-1/3.8	<b>25</b>
X11-1/4.3	<b>27</b>
X11-1/4.9	<b>29</b>
X11-1/5.9	<b>31</b>
X11-1/6.5	<b>32</b>
X11-1/7.8	<b>34</b>
X11-1/9.8	<b>36</b>

Standard bodies				
Displacement cm3/rev	Standard threads			
	0.9	I - I	B - B	J - J
1.2	I - I	B - B	J - J	G - F
1.7	I - I	B - B	J - J	G - F
2.2	I - I	B - B	J - J	G - F
2.6	I - I	B - B	J - J	G - F
3.2	I - I	B - B	J - J	G - F
3.8	I - I	B - B	J - J	G - F
4.3	I - I	B - B	J - J	G - F
4.9	I - I	B - B	J - J	G - F
5.9	I - I	B - B	J - J	G - F
6.5	I - I	B - B	J - J	G - F
7.8	I - I	B - B	J - J	G - F
9.8	I - I	B - B	J - J	G - F

Table showing standard flange and thread combinations available in stock

Body (threads/flanges)													
	<b>A</b>		<b>B</b>		<b>C</b>		<b>D</b>		<b>E</b>		<b>F</b>		<b>G</b>
	<b>H</b>		<b>I</b>		<b>J</b>	<b>Closed Body</b>	<b>Z</b>						