

intermediate pump - series XV

XO1-1

INTERMEDIATE PUMP TO BE COUPLED WITH XV1
FEMALE Ø25,4 FLANGE

X 0 I 06 32 A B B A

Series	X	series XV
Group	0	group 0
Category	I	intermediate pump
Displacement	06	0.76
Flange	32	Ø25.4 female right rotation 1P+0P
Shaft	A	CIP01 - Intermediate for 1+0 - 2+0 (Parallel ø7 - M7x1 - key thk. 2)
Body	IN	inlet - 1/4" GAS
	OUT	outlet - 1/4" GAS
Cover	A	ø22 female cover for left multiple pump element

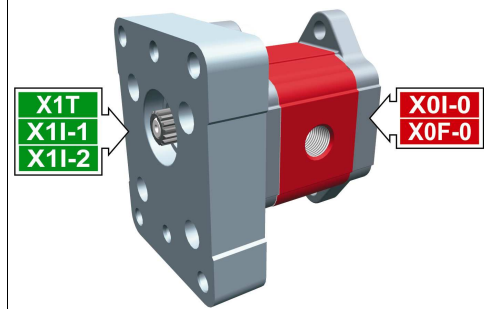

XI003

Technical data table

TYPE	Displacement cm3/rev	Max. Pressure		CODE	
		P1 bar	P3 bar	Left rotation	Right rotation
XO1-1/0.17	0,16	220	260	X 0 I 01 31 A B B A	X 0 I 01 32 A B B A
XO1-1/0.25	0,24	220	260	X 0 I 02 31 A B B A	X 0 I 02 32 A B B A
XO1-1/0.45	0,45	220	280	X 0 I 04 31 A B B A	X 0 I 04 32 A B B A
XO1-1/0.57	0,56	220	280	X 0 I 05 31 A B B A	X 0 I 05 32 A B B A
XO1-1/0.76	0,75	220	280	X 0 I 06 31 A B B A	X 0 I 06 32 A B B A
XO1-1/0.98	0,92	220	280	X 0 I 07 31 A B B A	X 0 I 07 32 A B B A
XO1-1/1.27	1,26	220	280	X 0 I 09 31 A B B A	X 0 I 09 32 A B B A
XO1-1/1.52	1,48	220	280	X 0 I 11 31 A B B A	X 0 I 11 32 A B B A
XO1-1/2.30	2,28	190	210	X 0 I 13 31 A B B A	X 0 I 13 32 A B B A

P1) Max. working pressure - P3) Max. peak pressure

For heavy-duty applications, it is recommended to check the admissible torque of the shaft

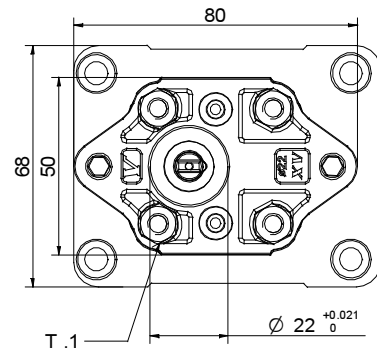

T.2

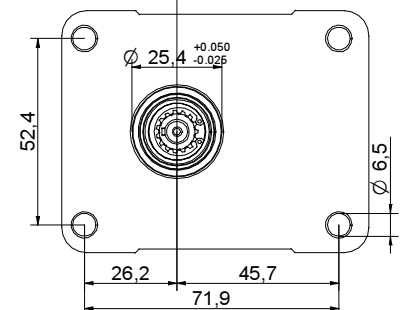
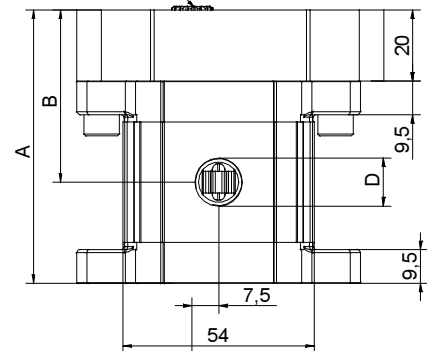

0104/08 X010632ABBA.dff

T.1 = 11.7÷13.7 [Nm] - screw tightening torque M6

T.2 = 2.1 [Nm] - admissible shaft torque (N.B. When choosing a shaft, always check the admissible torque).

Table of variations

XOI-1

Female $\varnothing 25,4$ FLANGE

Female $\varnothing 25,4$ FLANGE		Shaft		Cover		
Left rotation	Right rotation			Left rotation	Right rotation	
		CIP01 - Parallel T.2 = 2.1 [Nm] 	A			A
						D

Displacement	
TYPE	CODE
XOI-1/0.17	01
XOI-1/0.25	02
XOI-1/0.45	04
XOI-1/0.57	05
XOI-1/0.76	06
XOI-1/0.98	07
XOI-1/1.27	09
XOI-1/1.52	11
XOI-1/2.30	13

Standard bodies	
Displacement cm ³ /rev standard thread	
0.17	B - B
0.25	B - B
0.45	B - B
0.57	B - B
0.76	B - B
0.98	B - B
1.27	B - B
1.52	B - B
2.30	B - B

Table showing standard flange and thread combinations available in stock

Body (threads/flanges)													
	A		B		C		D		E		F		G
	H		I	Closed Body		Z							