

**Code:**

9RG NN O CC CC

|     |                                 |
|-----|---------------------------------|
| 9RG | Flow Divider Typology           |
| NN  | Number of flow divider elements |
| O   | Number of motor elements        |
| CC  | Motor Displacement Code         |
| CC  | Flow Divider Displacement Code  |

**Example:** Flow divider with two elements (same displacement) and Motor RV-0G / 0,76 x 2 + 1 Motor 1.52

9RG 02 1 11 06

**Example:** Flow Divider 4 elements (different displacement - max 6) and Motor: RV-0G / 0,57+0,76+1.27+0.45 + 1 Motor 2.30

9RG 04 1 13 05 06 09 04

**NOTE:** to define codes for flow dividers with more than 6 different displacement, please contact our sales department.

**Table: 1**

| Displacem.<br>Cm <sup>3</sup> /rev | CC<br>Code | Max<br>Pressure<br>bar | One element flow rate<br>l/min |             |      |
|------------------------------------|------------|------------------------|--------------------------------|-------------|------|
|                                    |            |                        | MIN                            | RECOMMENDED | MAX  |
| 0,17                               | 01         | 210                    | 0,2                            | 0,4         | 1,2  |
| 0,25                               | 02         | 210                    | 0,3                            | 0,7         | 1,8  |
| 0,45                               | 04         | 210                    | 0,6                            | 1,2         | 3    |
| 0,57                               | 05         | 210                    | 0,8                            | 1,5         | 3,8  |
| 0,76                               | 06         | 210                    | 1                              | 2           | 4,8  |
| 0,98                               | 07         | 210                    | 1,2                            | 2,3         | 5,6  |
| 1,27                               | 09         | 210                    | 1,5                            | 3           | 7,2  |
| 1,52                               | 11         | 210                    | 1,9                            | 3,5         | 8    |
| 2,30                               | 13         | 210                    | 2,6                            | 5           | 10,3 |

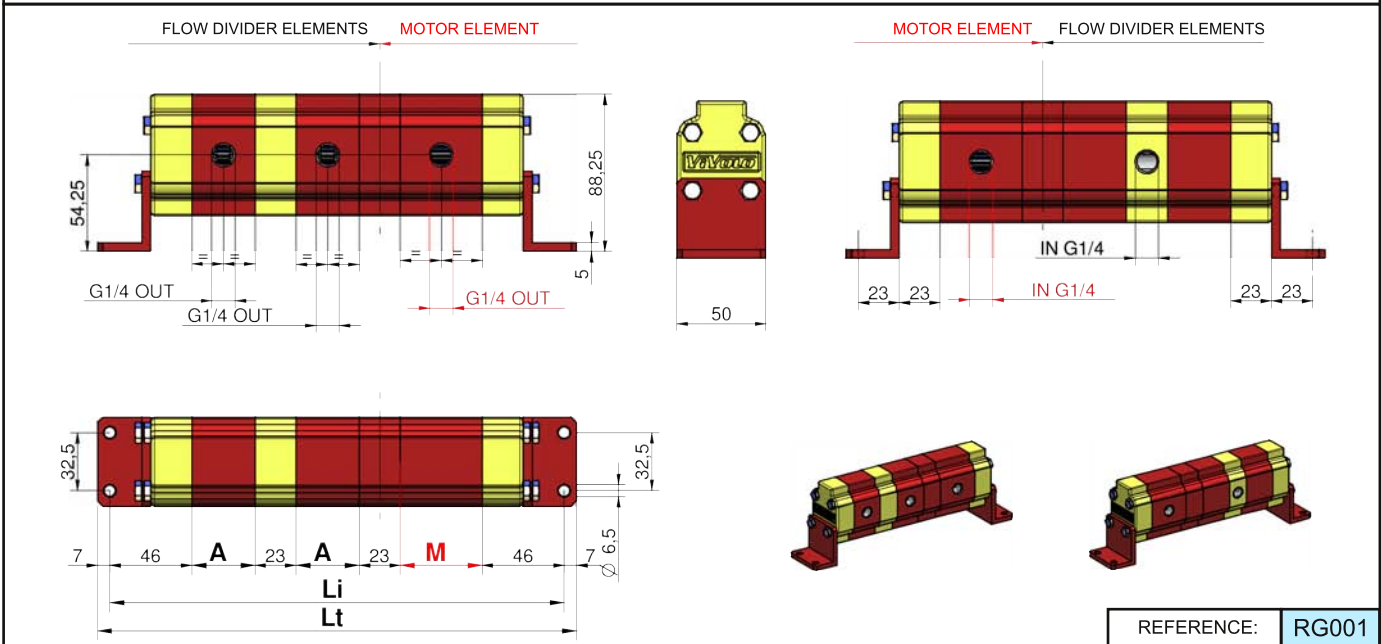

**Table: 2**

**Li = Distance between fixing hole centres (single displacement flow divider)**

| Cm <sup>3</sup> /rev | A-M  | Number of elements |       |       |       |       |       |       |       |     |       |       |       |       |       |       |
|----------------------|------|--------------------|-------|-------|-------|-------|-------|-------|-------|-----|-------|-------|-------|-------|-------|-------|
|                      |      | 2                  | 3     | 4     | 5     | 6     | 7     | 8     | 9     | 10  | 11    | 12    | 13    | 14    | 15    | 16    |
| 0,17                 | 29,3 | 174,8              | 227,7 | 280,6 | 333,5 | 386,4 | 439,3 | 492,5 | 545,1 | 598 | 650,9 | 703,8 | 756,7 | 809,6 | 862,5 | 915,4 |
| 0,25                 | 29,9 | 178                | 232,5 | 287   | 341,5 | 396   | 450,5 | 505   | 559,5 | 614 | 668,5 | 723   | 777,5 | 832   | 886,5 | 941   |
| 0,45                 | 31,5 | 180                | 235,5 | 291   | 346,5 | 402   | 457,5 | 513   | 568,5 | 624 | 679,5 | 735   | 790,5 | 846   | 901,5 | 957   |
| 0,76                 | 34   | 183                | 240   | 297   | 354   | 411   | 468   | 525   | 582   | 639 | 696   | 753   | 810   | 867   | 924   | 981   |
| 0,98                 | 35,5 | 186                | 244,5 | 303   | 361,5 | 420   | 478,5 | 537   | 595,5 | 654 | 712,5 | 771   | 829,5 | 888   | 946,5 | 1005  |
| 1,27                 | 38   | 191                | 252   | 313   | 374   | 435   | 496   | 557   | 618   | 679 | 740   | 801   | 862   | 923   | 984   | 1045  |
| 1,52                 | 40   | 195                | 258   | 321   | 384   | 447   | 510   | 573   | 636   | 699 | 762   | 825   | 888   | 951   | 1014  | 1077  |
| 2,30                 | 46   | 207                | 276   | 345   | 414   | 483   | 552   | 621   | 690   | 759 | 828   | 897   | 966   | 1035  | 1104  | 1173  |

**Table: 3** in this table the number of inlets in function of the number of elements are indicated.

| Number of elements    | 2 | 3 | 4 | 5 | 6 | 7 | 8 | 9 | 10 | 11 | 12 | 13 | 14 | 15 | 16 |
|-----------------------|---|---|---|---|---|---|---|---|----|----|----|----|----|----|----|
| "IN" Number of inlets | 1 | 1 | 2 | 2 | 3 | 3 | 4 | 4 | 5  | 5  | 6  | 6  | 7  | 7  | 8  |

**INTERNAL DRAIN**

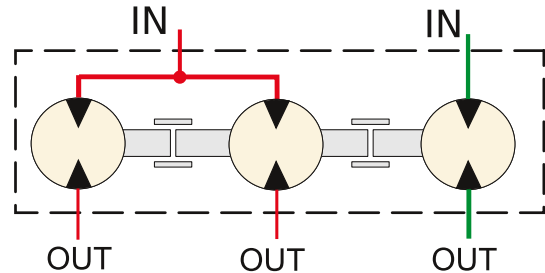
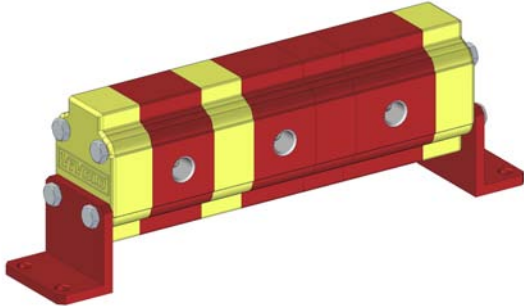

In **table 1** the functioning range of single flow divider elements is indicated.

The higher is the feeding capacity ( q ), the higher is the precision of the flow division, but in opposition there are losses of loading and higher noise. Therefore we suggest to feed the elements with capacities equal or a few superior to the ones indicated in the column "**RECOMMENDED**".

Remember to verify the capacities even in phase of flow reunion.

The pressure indicated are to be considered as maximum of functioning, the flow divider is able to bear peaks of pressure 20 % superior.

**How to calculate the "Li" and "Lt" measures of flow dividers:**

From **table 2** it is possible to obtain the "Li" measure for flow dividers up to 16 elements with equal displacements; for flow dividers with different elements or with more than 16 elements the "Li" and "Lt" measure have to be calculated by the following formula:

$$Li = [(n-1) \times 23] + 92 + (A1 + A2 + A3 + \dots)$$

$$92 = 46 + 46$$

n = Number of elements of flow divider

A1... An = heights of elements of flow divider

$$Lt = Li + 14$$

$$14 = 7 + 7$$

**EXAMPLE:** To obtain the measures Li and Lt of a flow divider with three elements (n=3), **RV-0G / 0,98 x 2+ 1 MOTOR 2,30**

Distance between fixing hole centres

$$Li = [(3-1) \times 23] + 92 + 35,5 + 35,5 + 46 = 255 \text{ mm}$$

Total Length

$$Lt = 245,5 + 14 = 269$$

In **table 3** the number of inlets in fuction of the number of elements are indicated.

For flow dividers with many inlets, as they are all communicating it is even possible to use only one of them, by plugging the other ones. We suggest to make full us at least of 1 inlet every 15 l/min capacity.

To obtain errors of division **inferior to 3%** there must be no difference of pressure between the elements superior to **30 bar**. To obtain high precisions the respect of the following parametres is also important:

- Enviroment temperature: -10°C ÷ +60°C                      Oil temperature: +30°C ÷ +60°C
- Hydraulic oil based on hlp, hv (din 51524) minerals      Oil Viscosity 20 ÷ 40 cSt
- Oil filtering 10 ÷ 25 µ