



F.LLI TOGNETTA S.P.A.

PNEUMATIC AND HYDRAULIC COMPONENTS

FLOW CONTROL VALVE FT 2252/2-02

90° DOUBLE-ACTING FLOW RATE CONTROL VALVE

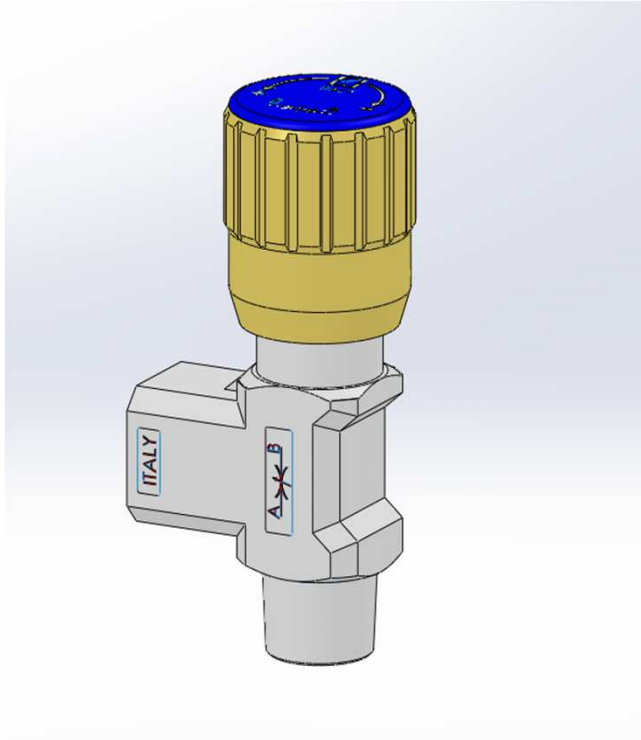

Characteristics

TYPE	FLOW SECTION	WORKING PRESSURE	BURSTING PRESSURE	WORKING TEMPERATURE	FILTRATION
14	12.57 mm ²	350 bar	1600 bar	-20/+100°C	25 Microns
38	19.64 mm ²	350 bar	1600 bar	-20/+100°C	25 Microns
12	50.27 mm ²	350 bar	1600 bar	-20/+100°C	25 Microns

Description

Double-acting flow rate control valve. Its realization allows a precise metallic sealing, linearity of fluid in the port, accurate check for a large flow rate range, suitable for panel mounting by a proper nut on request.

The contents are presented only for illustrative purpose, they do not constitute warranty for the products showed, as well as for their use and application. F.LLI TOGNETTA S.p.A. reserves the right of changing the specifics of these items anytime and without notice.

head office: 21019 somma lombardo (va) · via goito, 60 · tel. 0331.988.411 · telefax 0331.988.499 · corporate capital € 1.000.000

rea varese n.70107 · VAT number 00185410123 · iscriz. busto a. n. 12870

e-mail : tognella@tognella.it · www.tognella.it



F.LLI TOGNETTA S.P.A.

PNEUMATIC AND HYDRAULIC COMPONENTS

ORDER CODES

FT	2252/	2-	02-	14	-MP - To omit for standard handwheel - MP - plastic handwheel
Valve type					
Flow control					
Function				Size	
Double-acting				14-38-12	
		Connection			
		01 - Female - Female			
		02 - Male - Female			

TECHNICAL DATA

Flow rate and pressure drop depending on handwheel turns	See graphics	
Assembly position	In line or panel mounting	
Max. working pressure	bar	350
Recommended viscosity	cSt	10-220
Fluid temperature	°C	.-20 / + 100
Handwheel handling at max. pressure	N/m	5
Fluid contamination class	ISO 19/16 - filtri 25 µm e β25 ≥ 75 (recommended)	
Seals	Standard FPM	
Materials		
Body valve	Stainless steel 316	
Needle regulation group	Stainless steel 316	
Regulation handwheel	Aluminium GD AISi 12 or Plastic	
Surface protection	Chemical polishing	

head office: 21019 somma lombardo (va) via goito, 60 tel. 0331.988.411 telefax 0331.988.499 corporate capital € 1.000.000

rea varese n.70107 VAT number 00185410123 iscriz. busto a. n. 12870

e-mail : tognella@tognella.it • www.tognella.it

90° DOUBLE-ACTING FLOW RATE CONTROL VALVE

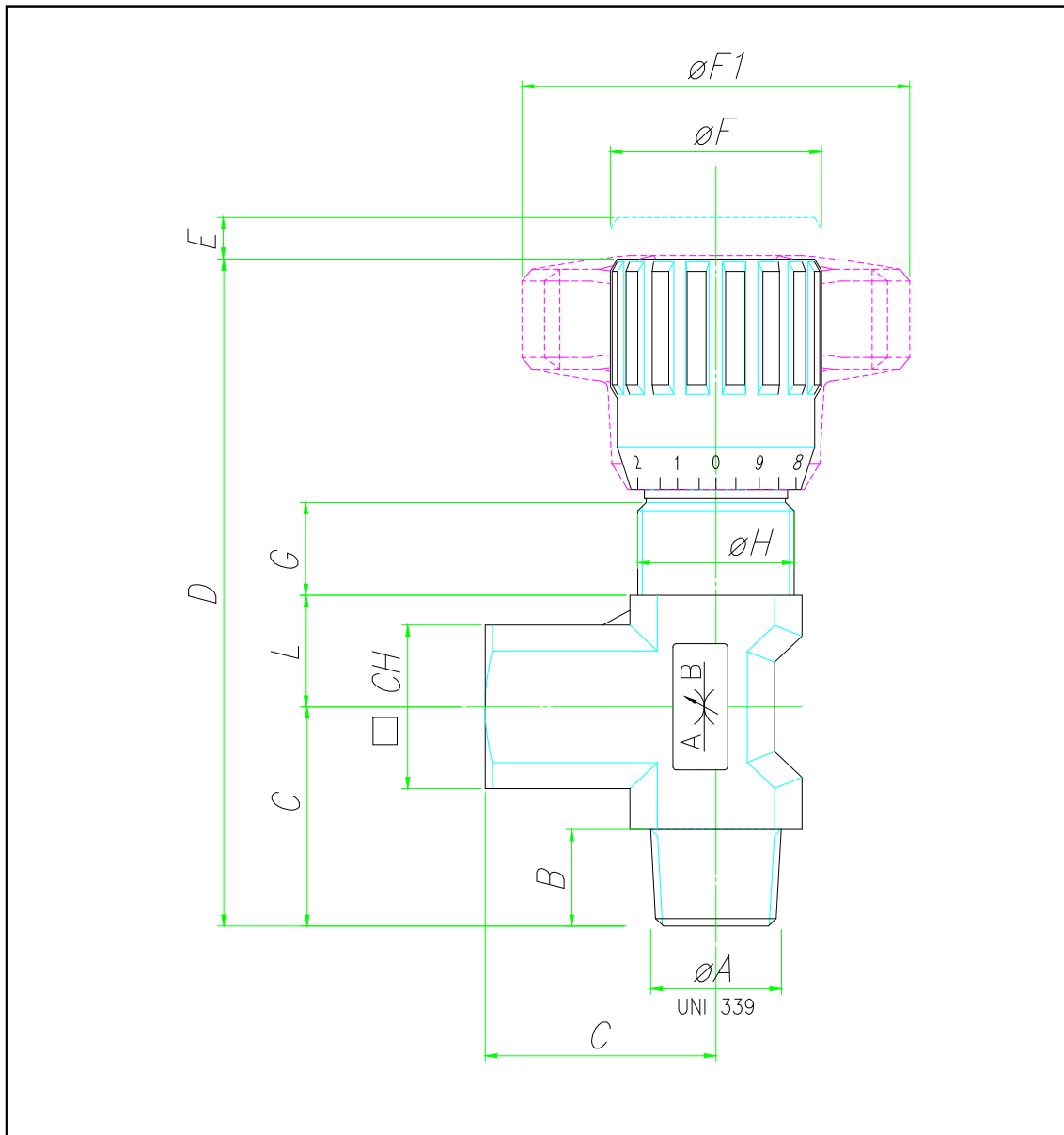

	ϕA	B	C	D	E	ϕF	$\phi F1$	G	ϕH	L	CH	KG
14	1/4"G	12	25	74,5	4,5	22	40	12	M17 x 1	11	18	0,125
38	3/8"G	13	29,5	88	7	27	50	11,5	M20 x 1	15	22	0,228
12	1/2"G	16	36	105	10	33	70	13	M25 x 1,5	19	27	0,418

head office: 21019 somma lombardo (va) via goito, 60 tel. 0331.988.411 telefax 0331.988.499 corporate capital € 1.000.000

rea varese n.70107 VAT number 00185410123 iscriz. busto a. n. 12870

e-mail : tognella@tognella.it • www.tognella.it



F.LLI TOGNELLA S.P.A.

PNEUMATIC AND HYDRAULIC COMPONENTS

GRAPHICS

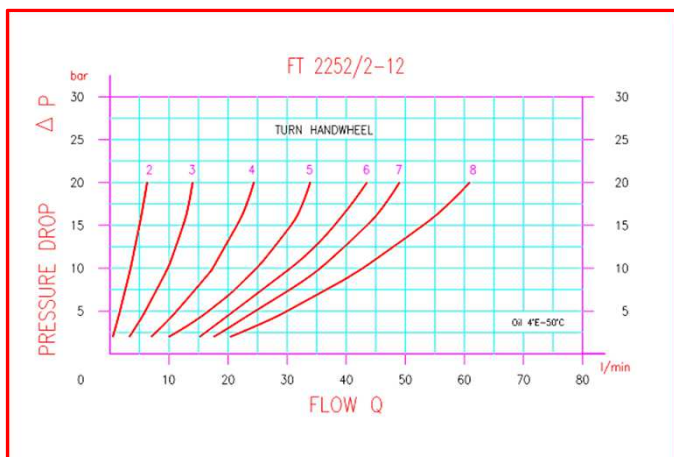
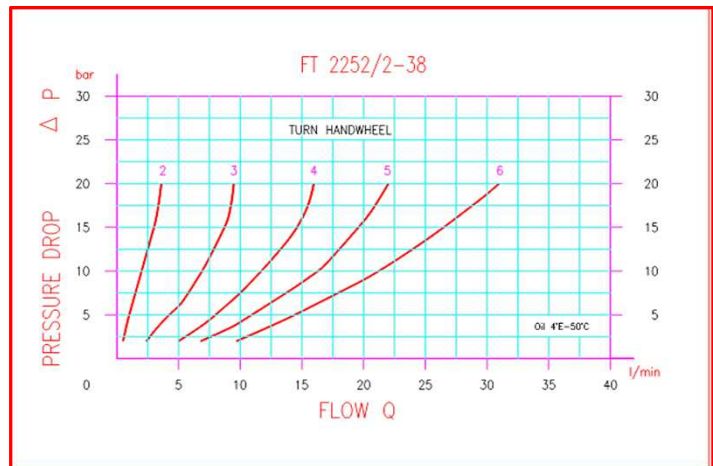
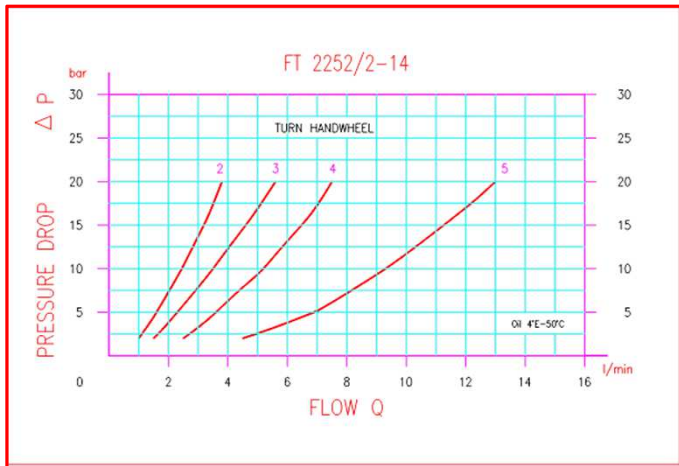

head office: 21019 somma lombardo (va) via goito, 60 tel. 0331.988.411 telefax 0331.988.499 corporate capital € 1.000.000
rea varese n.70107 VAT number 00185410123 iscriz. busto a. n. 12870
e-mail : tognella@tognella.it • www.tognella.it