



VP*-P*-MU

HYDRO-PILOT OPERATED CHECK VALVES SERIES 12

SUBPLATE MOUNTING
ISO 5781 (CETOP 06 07)

p max **320** bar
Q max (see table of performances)

OPERATING PRINCIPLE

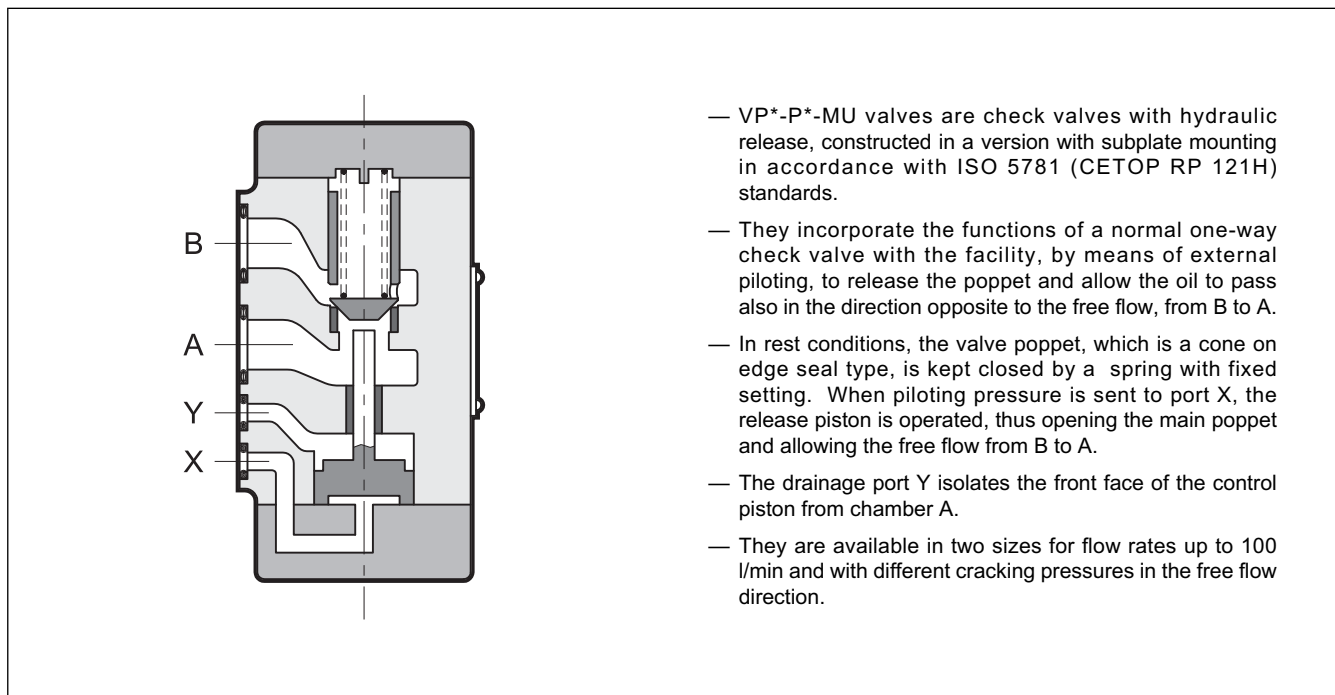

PERFORMANCES (working with mineral oil of viscosity of 36 cSt at 50°C)

		VP3	VP5
Maximum operating pressure	bar	320	320
Nominal flow rate	l/mn	50	100
Piloting ratio between release piston and sealed chamber areas	VP*-P*-MU	3,4:1	2,7:1
Piloting ratio with decompression device	VP*-P*/P-MU	12:1	14:1
Ambient temperature range	°C	-20 / +50	
Fluid temperature range	°C	-20 / +80	
Fluid viscosity range	cSt	10 ÷ 400	
Fluid contamination degree	According to ISO 4406:1999 class 20/18/15		
Recommended viscosity	cSt	25	
Mass	kg	3,7	6

HYDRAULIC SYMBOL

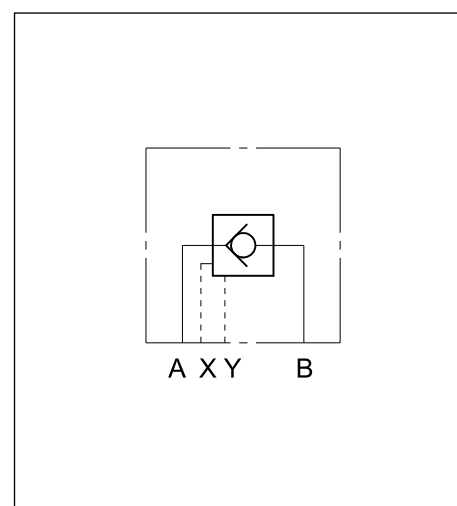

1 - IDENTIFICATION CODE

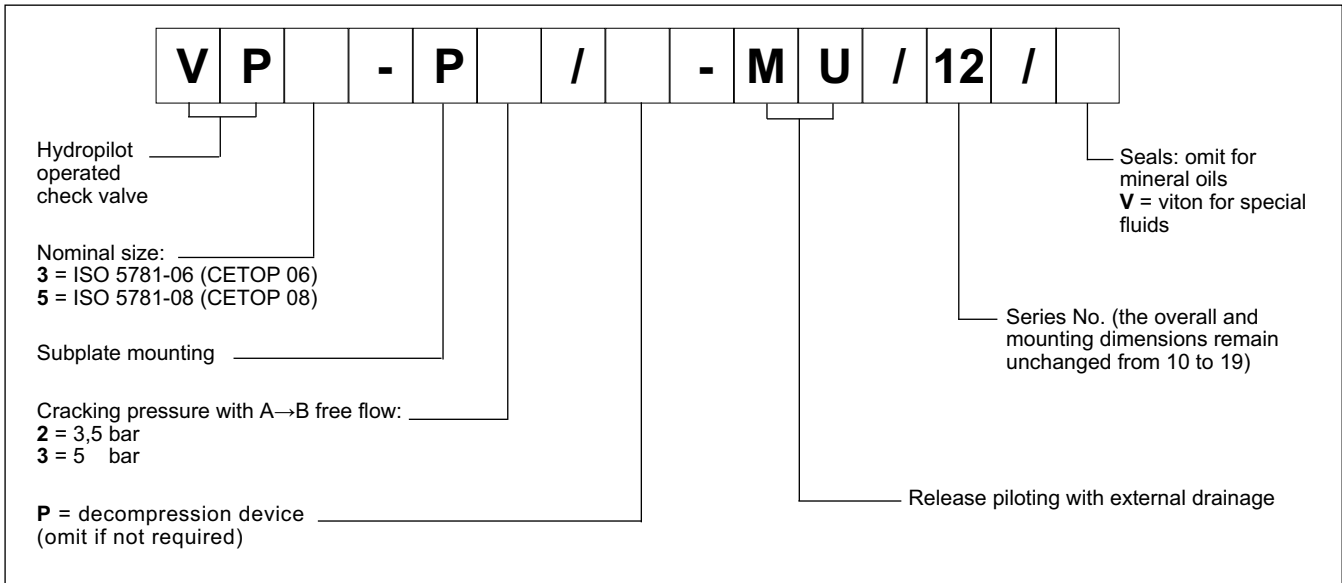

2 - CHARACTERISTIC CURVES (values obtained with viscosity 36 cSt at 50°C)

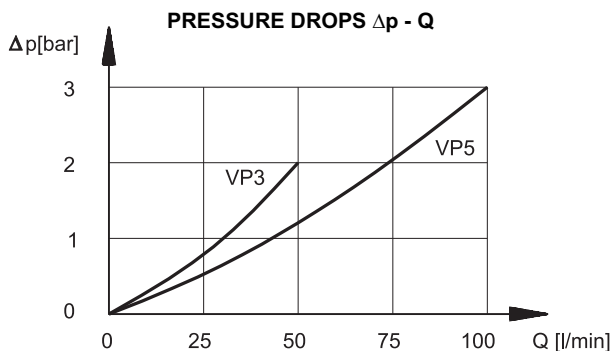

NOTE: The curves shown in the graph refer to B→A and A→B flow with the valve released hydraulically. For A→B flow, with the valve not released hydraulically, add the cracking pressure to the values shown.

3 - HYDRAULIC FLUIDS

Use mineral oil-based hydraulic fluids HL or HM type, according to ISO 6743-4. For these fluids, use NBR seals. For fluids HFDR type (phosphate esters) use FPM seals (code V). For the use of other kinds of fluid such as HFA, HFB, HFC, please consult our technical department. Using fluids at temperatures higher than 80 °C causes a faster degradation of the fluid and of the seals characteristics.

The fluid must be preserved in its physical and chemical characteristics.

4 - VP3-P*-MU OVERALL AND MOUNTING DIMENSIONS

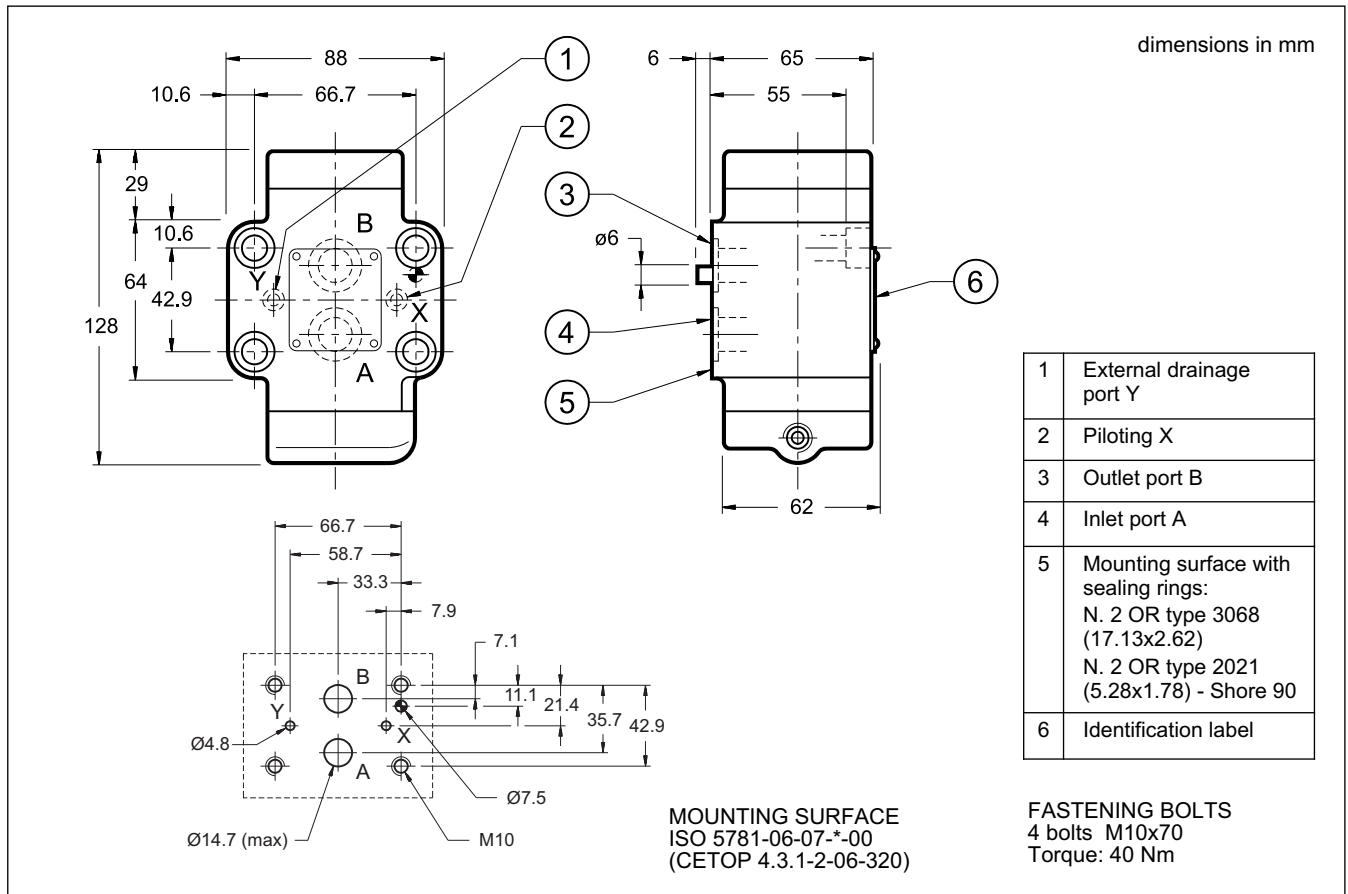

5 - VP5-P*-MU OVERALL AND MOUNTING DIMENSIONS

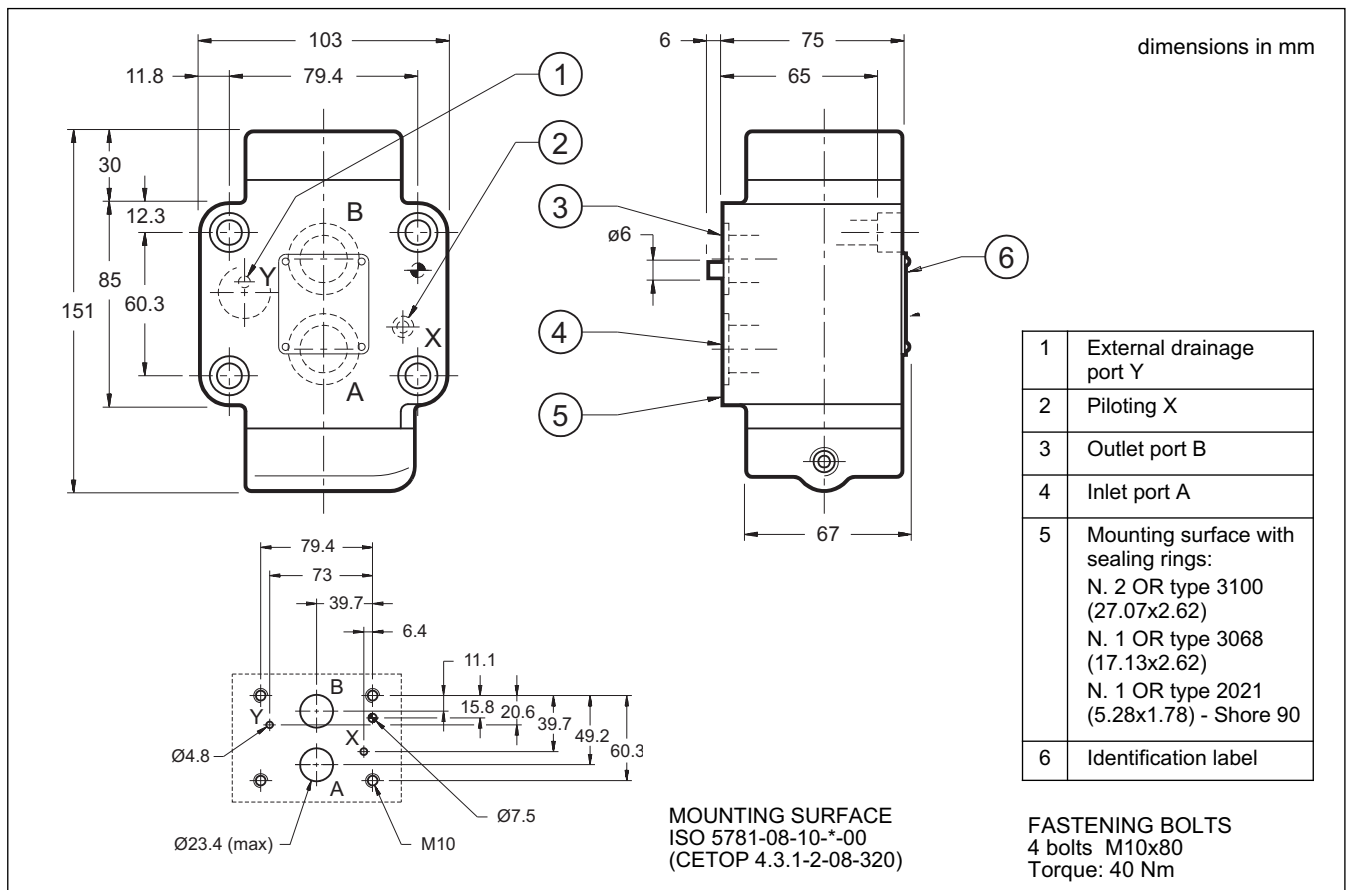



6 - USE

The VP*-P*-MU check valves with hydraulic release are used in circuits where the position of the actuators must be maintained even in the absence of hydraulic power.

They are available in two versions with the following characteristics:

VP*-P*-MU The VP*-P*-MU valves are check valves with hydraulic release that incorporate the functions of a normal one-way check valve with the possibility to release the poppet by means of external piloting, thus allowing flow of the oil also in the opposite direction of the free flow, from B to A. The valve poppet, a cone on edge seal type, is kept closed by a spring with fixed setting during rest conditions. When pilot pressure is sent to port X, the release piston is activated and opens the main poppet, thus allowing the reverse flow.

These valves have hydraulic isolation of the front face of the release piston from chamber A of the valve, by external drainage Y. This solution eliminates problems which can occur if, during the release phase of the valve, pressure builds up in chamber A near to or greater than the piloting pressure X, causing a backward movement of the piston and thus unwanted closure of the valve.

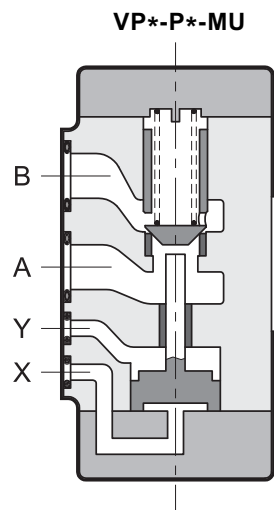

VP*-P*/P-MU The VP*-P*/P-MU valves are check valves with hydraulic release that, in addition to the characteristics of the preceding version, are equipped with a decompression device.

They are recommended when operating with high working pressures or with high loads that act as pressure multipliers.

The circuit (chamber B) is decompressed prior to complete opening of the valve during the release phase.

This prevents pressure shocks in the circuit and because of the high ratio existing between the areas of the control piston and the decompression device, release can occur even at a low piloting pressure.

Pilot pressure to port X operates the release piston which first opens the pre-opening poppet, causing decompression of the sealed chamber, it then opens the main poppet, allowing free flow from B to A.

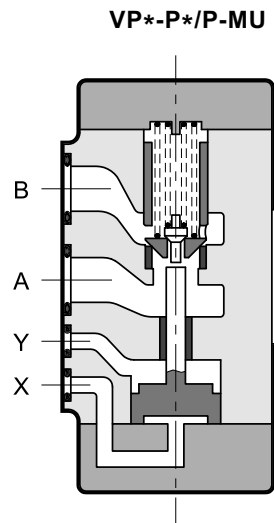

7 - SUBPLATES (see catalogue 51 100)

	VP 3	VP 5
Type	PMSZ3 - Al 4G with rear ports	PMSZ5 - Al6G with rear ports
A - B port dimensions	1/2" BSP	1" BSP
X - Y port dimensions	1/4" BSP	1/4" BSP



DIPLOMATiC OLEODiNAMIcA S.p.A.
 20015 PARABIAGO (MI) • Via M. Re Depaolini 24
 Tel. +39 0331.895.111
 Fax +39 0331.895.339
 www.diplomatic.com • e-mail: sales.exp@diplomatic.com