



Characteristics

SINGLE CHANNEL		DUAL CHANNEL
12 VDC / 24 VDC \pm 10%	Feeding voltage (stabilized)	12 VDC / 24 VDC \pm 10%
10 \div 30 VDC	Feeding voltage (max)	10 \div 30 VDC
40 W	Max power absorption	40 W
2.8 A	Output max current	2.8A
+5V/ max. 10 mA	External potentiometer feeding (output)	+ 5V / max 10 mA
0 \div +2; 0 \div +5; 0 \div +10	Reference (input) Volt	-2 \div +2; -5 \div +5; -10 \div +10 ;0 \div +5
0 \div 1A	Bias voltage adjustment (I.min)	0 \div 1°
0 \div 10 sec	Adjustment Ramp Time	0 \div 10 sec
1 Volt = 1 Ampere	Output signal test point (Valve current)	1 Volt = 1 Ampere
-20/70°C	Ambient operating temperature	-20/70°C
0.10 Kg	Weight	0.12 Kg

It is suggested, in order to avoid electromagnetic interference, to install a 2200 μ F capacitor for each Ampere absorbed by the proportional valve.

Example. For 1 A max valve, install a capacitor, for 2 A max valve, install 2 capacitors in parallel near the driver on supply terminals.

It is also suggested to use a shielded and plated cable for reference potentiometer and a plated cable for the two conductors of proportional valve coil, reducing the EMC troubles.

Description

ISO electronic driver is suitable to control proportional valves in hydraulic systems. The pilot system is PWM and supply can be both 12 Vdc and 24 Vdc.

The driver is a card that can be supplied for installation on card guide, in rack or in "custom" boxes. It is generally supplied in a 8 or 11 pins base box to be mounted on an omega channel in compliance with DIN EN 50022 norms.

Panelboard

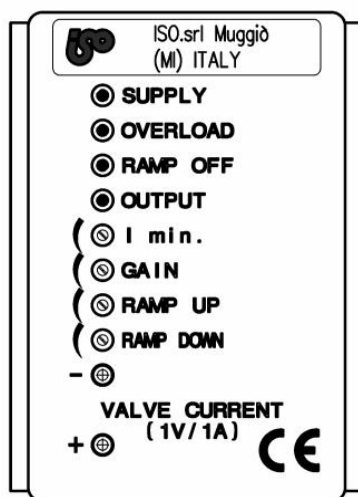

(SINGLE CHANNEL)

- SUPPLY** = 12 Vdc / 24 Vdc. Supply (green led)
- OVERLOAD** = Protection against overload (red led)
- RAMP OFF** = Ramps off (red led)
- OUTPUT** = Output current on solenoid (yellow led)
- I. MIN.** = Min. current adjustment (Bias)
- GAIN** = Gain adjustment (Scale)
- RAMP UP** = Ramp up time adjustment
- RAMP DOWN** = Ramp down time adjustment
- VALVE CURRENT** = On solenoid Current Test point (1V=1A)

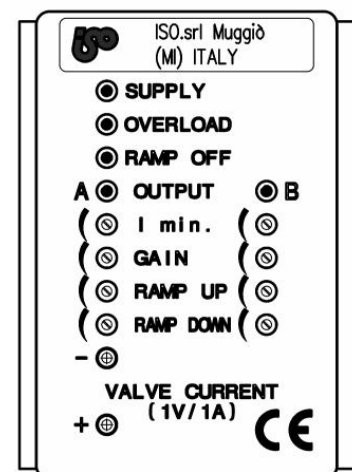

(DUAL CHANNEL)

ELECTRONIC REGULATOR FOR OPEN LOOP



Dimensions

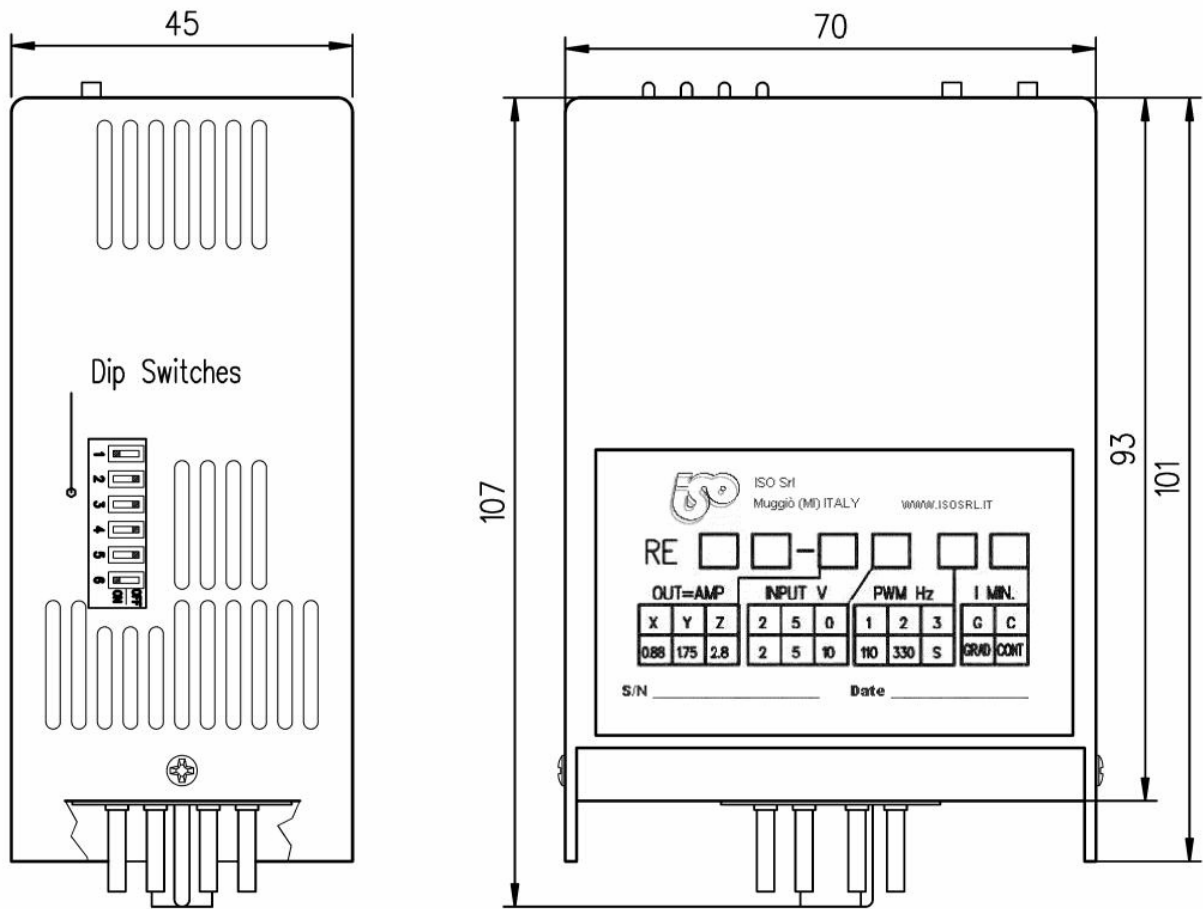

Diagram

Dual channel differential input reference

Dual channel positive input reference

Single channel reference signal

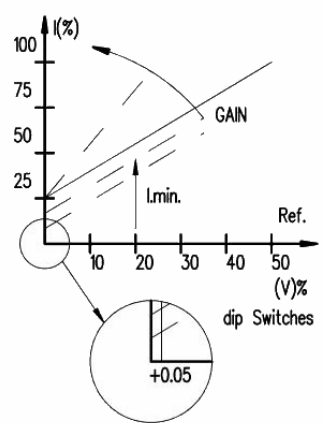
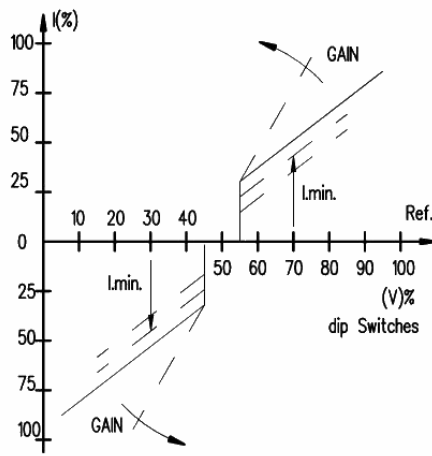
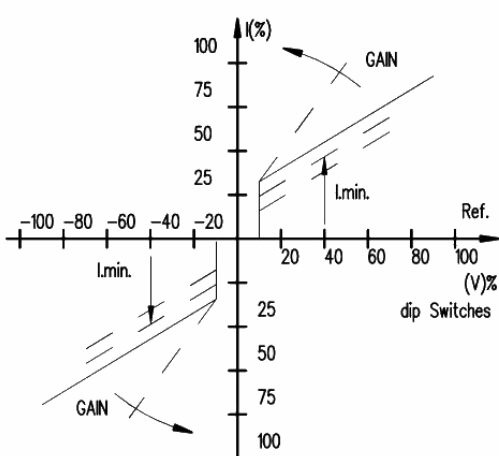



Blocks Diagram

OCTAL-SINGLE CHANNEL

- SUP (2-7) : External supply
- OUT (1-4) : Output for external potentiometer
- REF (3) : Reference
- SO (5-6) : Outputs to solenoid
- DR (8) : Ramps off (Closed contact = cut off)
- POT : Reference external potentiometer
- PWM : Amplitude modulated wave

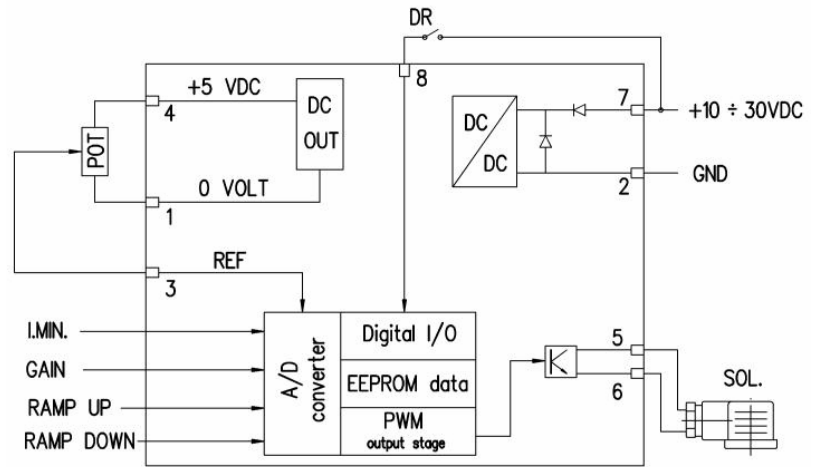

UNDECAL-SINGLE CHANNEL

- SUP (1-11) : External supply
- OUT (8-10) : Output for external potentiometer
- REF (9) : Reference
- SO (5-6) : Outputs to solenoid
- DR (2) : Ramps off (Closed contact = cut off)
- POT : Reference external potentiometer
- PWM : Amplitude modulated wave
- Pin (3,4,7) : Not Enabled

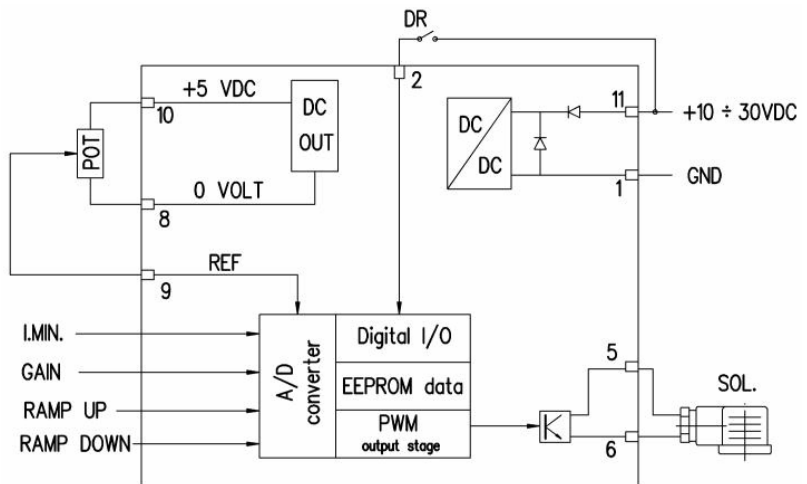

UNDECAL-DUAL CHANNEL

- SUP (1-11) : External supply
- OUT (8-10) : Output for external potentiometer
- REF (9) : Reference
- SO A (5-6) : Outputs to A solenoid
- SO B (5-7) : Outputs to B solenoid
- DR (3) : Ramps off (Closed contact = cut off)
- POT : Reference external potentiometer
- CS : Current feedback
- PWM : Amplitude modulated wave

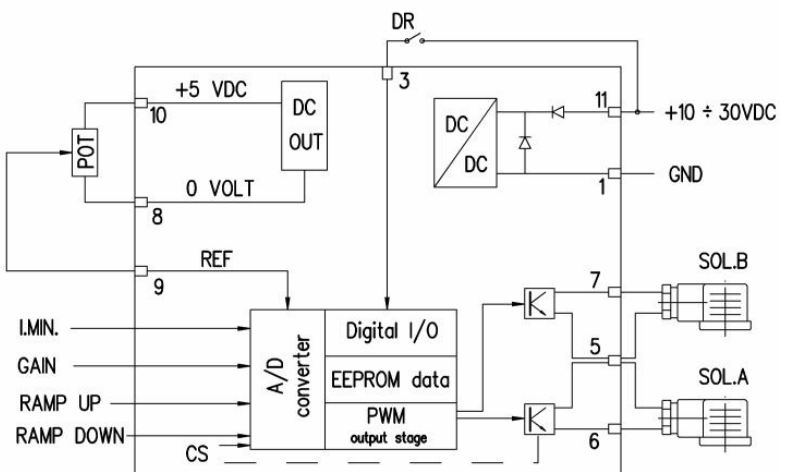



Starting up and setting

Procedure:

Connect the card properly according to the scheme of previous page without tension. Completely rotate clockwise the four adjusting trimmers, put the reference potentiometer on 0.

Before giving tension to the card, be sure that any unexpected movement of the hydraulic system can damage person or things. Give tension to the card: green led will light.

To read the tension (similar to the current in the valve) place a voltmeter between the red and black bush .

1V = 1A

Min current setting or bias current (BIAS):

Rotate the minimum current trimmer slowly (I MIN.) until you can see a visual movement of the actuator.

Rotate the trimmer clockwise completely: when the actuator stops moving, the minimum current is properly set.

Max current gain adjustment and ramp times (SCALE):

If the plant can be damaged by the too fast movement of the solenoid valve, rotate preliminarily the trimmers of ramp times of at least 10 turns clock wise (check the application carefully). The actuator max speed can now be adjusted. Set the potentiometer at max (reference signal) and slowly rotate the gain trimmer (GAIN) until the max speed is achieved. The speed can be adjusted by potentiometer lever.

Once the gain is set, the ramp times can be adjusted separately (time required to switch from the minimum current value to maximum current value and viceversa) according to the application.

Note:

- The ramp fall time influences the actuator stop position, therefore a proper adjustment is required.
- When red led is lighted (OVERLOAD), it is necessary to clear the card and then apply voltage after removing the overload cause.

DIP SWITCHES table:

On one side of the regulator there are 6 micro switches that are internally placed (see drawing). By operating on these switches, through the cooling slits, it is possible to set the regulator according to the application.

Dip switches table Single channel and Dual channel

DIP SW. SINGLE CHANNEL	FUNCTION									
	I max. (amp.)			Input ref. (volt)			PWM (Hz)		I min.	
	2.8	1.75	0.88	0:10	0:5	0:2	110	330	C	G
1							OFF	ON		
2									OFF	ON
3				OFF	ON	OFF				
4				OFF	OFF	ON				
5	OFF	ON	OFF							
6	OFF	OFF	ON							
REFERENCE CODE	Z	Y	X	0	5	2	1	2	C	G

DIP SW. DUAL CHANNEL	FUNCTION										
	I max. (amp.)			Input ref. (volt)				PWM (Hz)		I min.	
	2.8	1.75	0.88	-10:10	-5:5	0:5	-2:2	110	330		G
1								OFF	ON		
2										/	ON
3				OFF	ON	OFF					
4				OFF	OFF	ON					
5	OFF	ON	OFF								
6	OFF	OFF	ON								
REFERENCE CODE	Z	Y	X	0	5	2		1	2		G



Wirings

The schemes in the drawing show the possible types of wiring of ISO driver. In fact it can be used with multiple references, circuits and automatisms of different kind.

Wiring with potentiometers battery

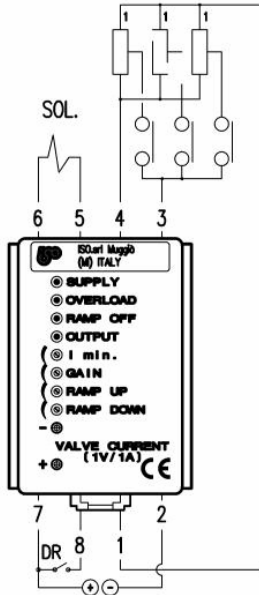

Wiring with PLC

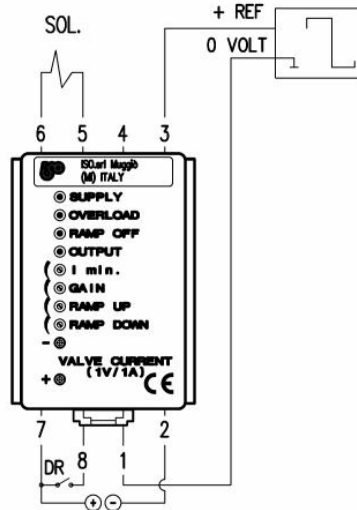

OCTAL-SINGLE CHANNEL

- PIN 1 = 0 V potentiometer
- PIN 2 = 0 V supply
- PIN 3 = Potentiometer spool (or PLC reference)
- PIN 4 = Positive potentiometer (5V)
- PIN 5 - 6 = Outputs to solenoid
- PIN 7 = +24 V supply
- PIN 8 = Disabled ramps

Wiring with potentiometers battery

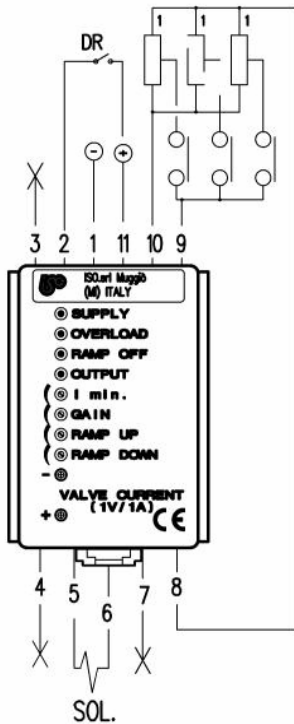

Wiring with PLC

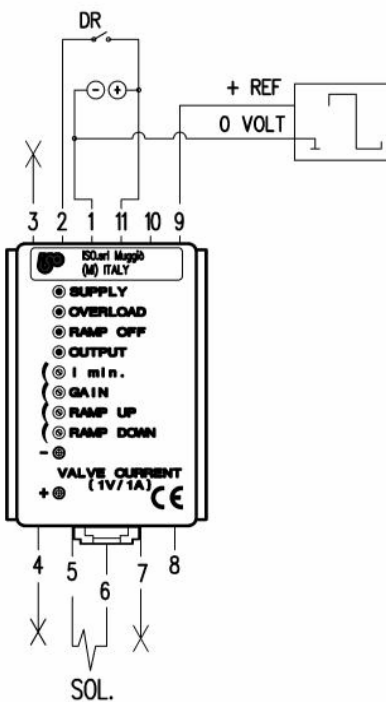

UNDECAL-SINGLE CHANNEL

- PIN 1 = 0 V supply
- PIN 2 = Disabled ramps
- PIN 3 = Disabled
- PIN 4 = Disabled
- PIN 5 - 6 = Outputs to solenoid
- PIN 7 = Disabled
- PIN 8 = Negative potentiometer
- PIN 9 = Potentiometer spool (or PLC reference)
- PIN 10 = Positive potentiometer (5V)
- PIN 11 = +24 V supply

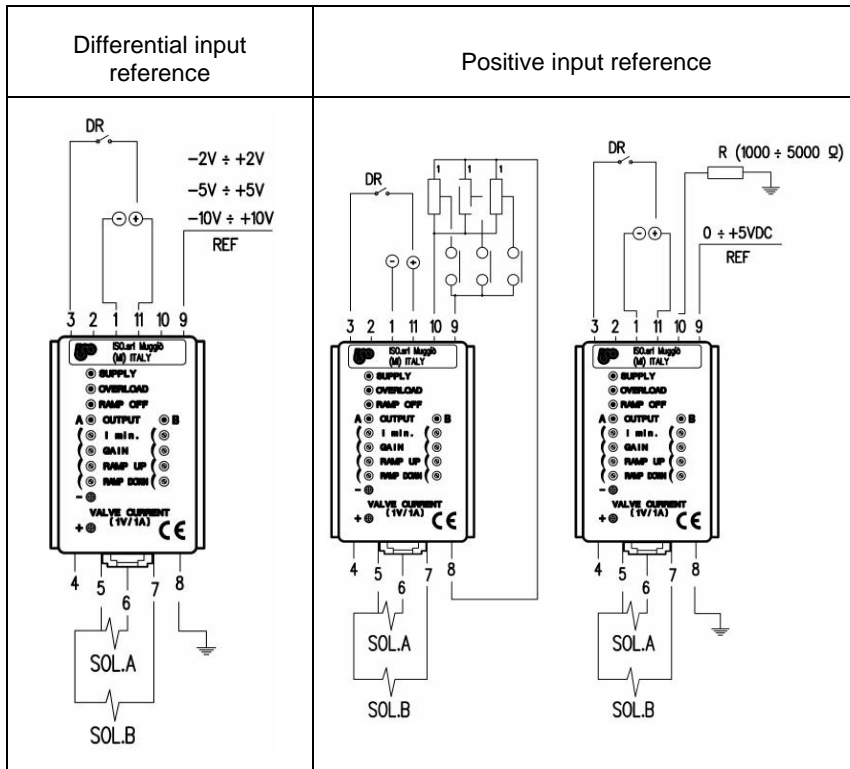

UNDECAL-DUAL CHANNEL

- PIN 1** = 0 V supply
- PIN 2** = Disabled ramps
- PIN 3** = Disabled ramps
- PIN 5 - 6** = Outputs to solenoid A
- PIN 5 - 7** = Outputs to solenoid B
- PIN 8** = Negative potentiometer (-5V)
- PIN 9** = Potentiometer spool (or PLC reference)
- PIN 10** = Positive Potentiometer (+5V)
- PIN 11** = +24 V supply

Ordering code

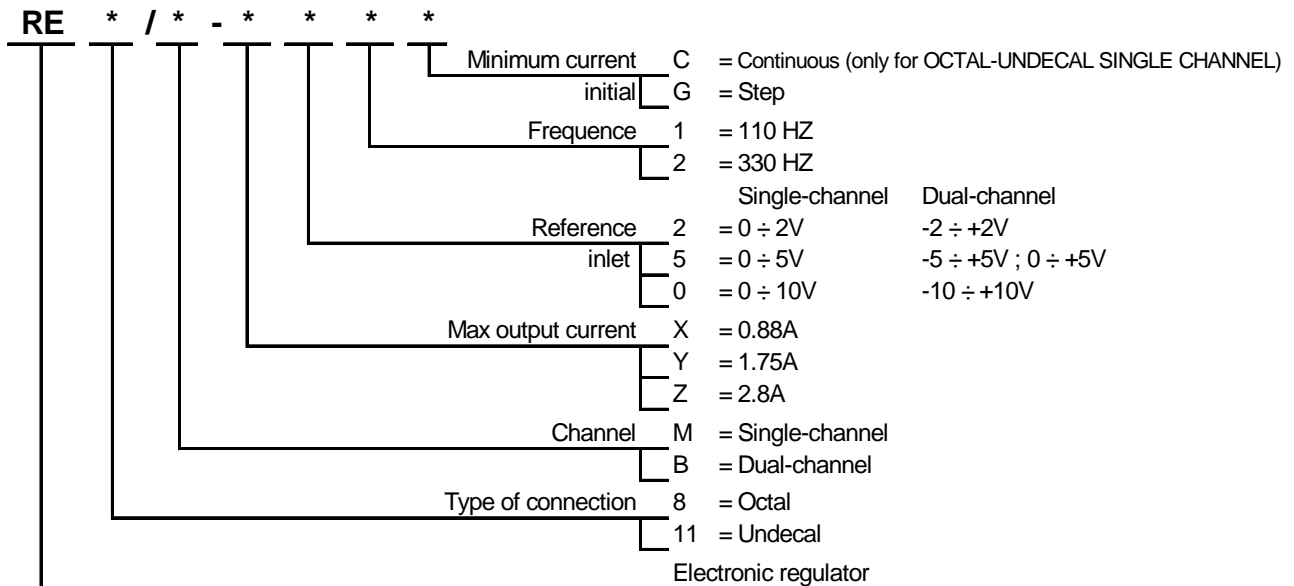

N.B. In case the ordering code have not specification of any element, the setting will be the following:

SINGLE CHANNEL	DUAL CHANNEL
Z51C: Z = 2.8A (I Max.) 5 = 0 : 5V (Ref.) 1 = 110Hz. (PWM) C = Continuous (I Min.)	Z51G: Z = 2.8A (I Max.) 5 = -5 ÷ +5V ; 0 ÷ +5V (Ref.) 1 = 110Hz. (PWM) G = Step (I Min.)