

# unidirectional motor - series XV

XV-1U

HY TYPE MOTOR  
 ø32 BODY-SHAPED FLANGE - MILLED SHANK

**X 1 U 25 52 D B B A**

Series	X	series XV
Group	1	group 1
Category	U	unidirectional motor
Displacement	25	3.8
Flange	52	Ø32 HY right rotation
Shaft	D	CF002 - Milled shank ø10 - thk.5
Body	IN	inlet - 3/8" GAS
	OUT	outlet - 3/8" GAS
Cover	A	standard



XU140

Technical data table

TYPE	Displacement cm3/rev	Max. Pressure		CODE	
		P1 bar	P3 bar	Left rotation	Right rotation
XV-1U/0.9	0,91	240	280	X 1 U 16 51 D B B A	X 1 U 16 52 D B B A
XV-1U/1.2	1,17	250	290	X 1 U 17 51 D B B A	X 1 U 17 52 D B B A
XV-1U/1.7	1,56	250	290	X 1 U 18 51 D B B A	X 1 U 18 52 D B B A
XV-1U/2.2	2,08	250	290	X 1 U 20 51 D B B A	X 1 U 20 52 D B B A
XV-1U/2.6	2,60	250	300	X 1 U 21 51 D B B A	X 1 U 21 52 D B B A
XV-1U/3.2	3,12	250	300	X 1 U 23 51 D B B A	X 1 U 23 52 D B B A
XV-1U/3.8	3,64	250	300	X 1 U 25 51 D B B A	X 1 U 25 52 D B B A
XV-1U/4.3	4,16	250	300	X 1 U 27 51 D B B A	X 1 U 27 52 D B B A
XV-1U/4.9	4,94	250	300	X 1 U 29 51 D B B A	X 1 U 29 52 D B B A
XV-1U/5.9	5,85	250	300	X 1 U 31 51 D B B A	X 1 U 31 52 D B B A
XV-1U/6.5	6,50	250	300	X 1 U 32 51 D B B A	X 1 U 32 52 D B B A
XV-1U/7.8	7,54	220	260	X 1 U 34 51 D B B A	X 1 U 34 52 D B B A
XV-1U/9.8	9,88	190	230	X 1 U 36 51 D B B A	X 1 U 36 52 D B B A

P1) Max. working pressure - P3) Max. peak pressure

For heavy-duty applications, it is recommended to check the admissible torque of the shaft

Dimensions table

TYPE	Weight kg	A	B	C	D	D
		mm	mm	mm	IN	OUT
XV-1U/0.9	0,950	77,1	36,3	65,1	3/8" BSPP	3/8" BSPP
XV-1U/1.2	0,970	78,0	36,8	66,0	3/8" BSPP	3/8" BSPP
XV-1U/1.7	1,010	79,5	37,5	67,5	3/8" BSPP	3/8" BSPP
XV-1U/2.2	1,030	81,5	38,5	69,5	3/8" BSPP	3/8" BSPP
XV-1U/2.6	1,060	83,5	39,5	71,5	3/8" BSPP	3/8" BSPP
XV-1U/3.2	1,090	85,5	40,5	73,5	3/8" BSPP	3/8" BSPP
XV-1U/3.8	1,120	87,5	41,5	75,5	3/8" BSPP	3/8" BSPP
XV-1U/4.3	1,170	89,5	42,5	77,5	3/8" BSPP	3/8" BSPP
XV-1U/4.9	1,200	92,5	44,0	80,5	3/8" BSPP	3/8" BSPP
XV-1U/5.9	1,260	96,0	45,8	84,0	3/8" BSPP	3/8" BSPP
XV-1U/6.5	1,300	97,5	47,0	85,5	3/8" BSPP	3/8" BSPP
XV-1U/7.8	1,360	102,5	49,0	90,5	3/8" BSPP	3/8" BSPP
XV-1U/9.8	1,500	111,5	53,5	99,5	3/8" BSPP	3/8" BSPP

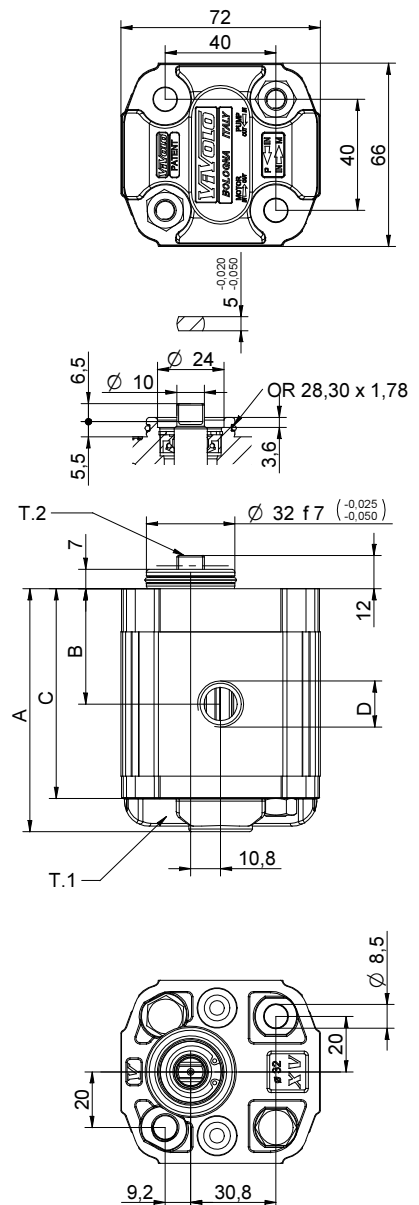

26/08/04 X1P25S2DBBA.dft

T.1 = 24.5÷29.4 [Nm] - screw tightening torque M8

T.2 = 13.8 [Nm] - admissible shaft torque (N.B. When choosing a shaft, always check the admissible torque).

# Table of variations

**XV-1U**

## ø32 "HY" Body-Shaped FLANGE

ø32 "HY" Body-Shaped FLANGE				Shaft				Cover			
Left rotation		Right rotation						Left rotation		Right rotation	
	<b>51</b>		<b>52</b>	CF002 - Milled shank T.2 = 13.8 [Nm] 	<b>D</b>	CO001 - Tapered T.2 = 43 [Nm] 	<b>F</b>			<b>A</b>	
	<b>53</b>		<b>54</b>	SCF02 - Splined T.2 = 42.8 [Nm] m=0,75 Z=15 	<b>L</b>	SCF04 - Splined T.2 = 22.6 [Nm] m=1,6 Z=6 DIN 5482 - 12x9 	<b>J</b>			<b>B</b>	
	<b>55</b>		<b>56</b>	SCF01 - Splined T.2 = 42.8 [Nm] m=0,75 Z=15 	<b>Q</b>	SCF03 - Splined T.2 = 42.8 [Nm] m=0,75 Z=15 	<b>R</b>			<b>C</b>	
	<b>57</b>		<b>58</b>							<b>D</b>	

Displacement	
TYPE	CODE
XV-1U/0.9	<b>16</b>
XV-1U/1.2	<b>17</b>
XV-1U/1.7	<b>18</b>
XV-1U/2.2	<b>20</b>
XV-1U/2.6	<b>21</b>
XV-1U/3.2	<b>23</b>
XV-1U/3.8	<b>25</b>
XV-1U/4.3	<b>27</b>
XV-1U/4.9	<b>29</b>
XV-1U/5.9	<b>31</b>
XV-1U/6.5	<b>32</b>
XV-1U/7.8	<b>34</b>
XV-1U/9.8	<b>36</b>

Standard bodies							
Displacement cm3/rev	Standard threads						
	0.9	I - I	B - B	J - J	B - Z	Z - Z	G - F
1.2	I - I	B - B	J - J	B - Z	Z - Z	G - F	
1.7	I - I	B - B	J - J	B - Z	Z - Z	G - F	
2.2	I - I	B - B	J - J	B - Z	Z - Z	G - F	
2.6	I - I	B - B	J - J	B - Z	Z - Z	G - F	
3.2	I - I	B - B	J - J	B - Z	Z - Z	G - F	
3.8	I - I	B - B	J - J	B - Z	Z - Z	G - F	
4.3	I - I	B - B	J - J	B - Z	Z - Z	G - F	
4.9	I - I	B - B	J - J	B - Z	Z - Z	G - F	
5.9	I - I	B - B	J - J	B - Z	Z - Z	G - F	
6.5	I - I	B - B	J - J	B - Z	Z - Z	G - F	
7.8	I - I	B - B	J - J	B - Z	Z - Z	G - F	
9.8	I - I	B - B	J - J	B - Z	Z - Z	G - F	

Table showing standard flange and thread combinations available in stock

		<b>N</b>
Internal drainage		
		<b>O</b>
External drainage		

Body (threads/flanges)													
	<b>A</b>		<b>B</b>		<b>C</b>		<b>D</b>		<b>E</b>		<b>F</b>		<b>G</b>
	<b>H</b>		<b>I</b>		<b>J</b>		<b>Z</b>						
Closed Body													