

entrainment pump - series XV

XOT

STANDARD DRIVING PUMP
 ø22 FLANGE - PARALLEL SHAFT

X 0 T 06 02 A B B A

Series	X	series XV
Group	0	group 0
Category	T	entrainment pump
Displacement	06	0.76
Flange	02	Ø22 right rotation
Shaft	A	CIP01 - Parallel ø7 - M7x1 - key thk. 2
Body	IN	inlet - 1/4" GAS
	OUT	outlet - 1/4" GAS
Cover	A	ø22 female cover for left multiple pump element

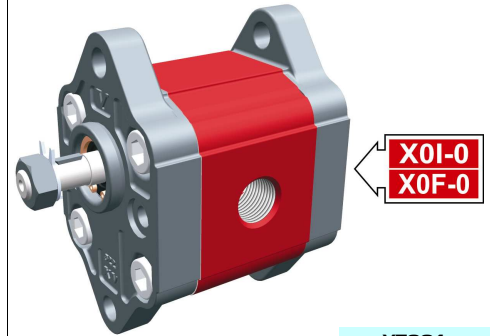

XT001

Technical data table						
TYPE	Displacement cm3/rev	Max. Pressure		CODE		
		P1 bar	P3 bar	Left rotation		Right rotation
XOT/0.17	0,16	220	260	X 0 T 01 01 A B B A	X 0 T 01 02 A B B A	X 0 T 01 02 A B B A
XOT/0.25	0,24	220	260	X 0 T 02 01 A B B A	X 0 T 02 02 A B B A	X 0 T 02 02 A B B A
XOT/0.45	0,45	220	280	X 0 T 04 01 A B B A	X 0 T 04 02 A B B A	X 0 T 04 02 A B B A
XOT/0.57	0,56	220	280	X 0 T 05 01 A B B A	X 0 T 05 02 A B B A	X 0 T 05 02 A B B A
XOT/0.76	0,75	220	280	X 0 T 06 01 A B B A	X 0 T 06 02 A B B A	X 0 T 06 02 A B B A
XOT/0.98	0,92	220	280	X 0 T 07 01 A B B A	X 0 T 07 02 A B B A	X 0 T 07 02 A B B A
XOT/1.27	1,26	220	280	X 0 T 09 01 A B B A	X 0 T 09 02 A B B A	X 0 T 09 02 A B B A
XOT/1.52	1,48	220	280	X 0 T 11 01 A B B A	X 0 T 11 02 A B B A	X 0 T 11 02 A B B A
XOT/2.30	2,28	190	210	X 0 T 13 01 A B B A	X 0 T 13 02 A B B A	X 0 T 13 02 A B B A

P1) Max. working pressure - P3) Max. peak pressure

For heavy-duty applications, it is recommended to check the admissible torque of the shaft

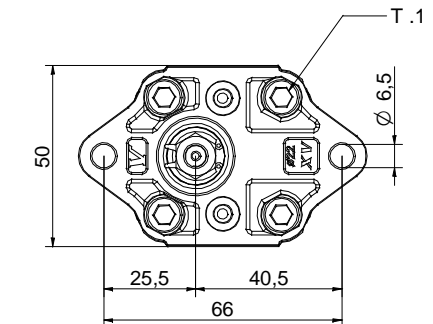
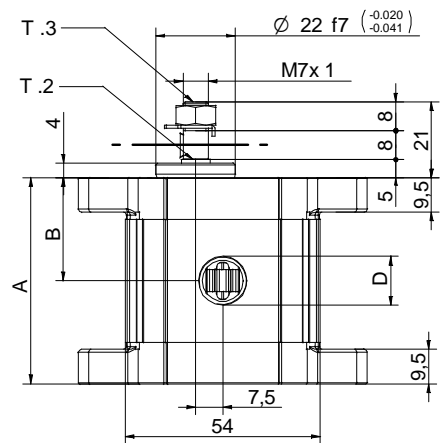
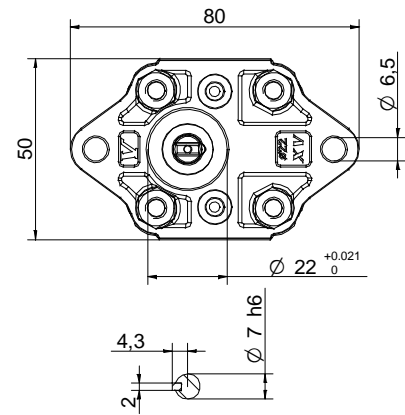

3103/08 XOT0602ABBA.dft

Dimensions table					
TYPE	Weight	A	B	D	D
	kg	mm	mm	IN	OUT
XOT/0.17	0,400	52,3	26,2	1/4" BSPP	1/4" BSPP
XOT/0.25	0,410	52,9	26,5	1/4" BSPP	1/4" BSPP
XOT/0.45	0,420	54,5	27,3	1/4" BSPP	1/4" BSPP
XOT/0.57	0,430	55,5	27,8	1/4" BSPP	1/4" BSPP
XOT/0.76	0,440	57,0	28,5	1/4" BSPP	1/4" BSPP
XOT/0.98	0,460	58,5	29,3	1/4" BSPP	1/4" BSPP
XOT/1.27	0,480	61,0	30,5	1/4" BSPP	1/4" BSPP
XOT/1.52	0,500	63,0	31,5	1/4" BSPP	1/4" BSPP
XOT/2.30	0,560	69,0	34,5	1/4" BSPP	1/4" BSPP

T.1 = 11.7÷13.7 [Nm] - screw tightening torque M6

T.3 = 11.5 [Nm] - torque wrench setting 11

T.2 = 2.1 [Nm] - admissible shaft torque (N.B. When choosing a shaft, always check the admissible torque).

Table of variations

XOT

Standard ø22 FLANGE

Standard ø22 FLANGE				Shaft				Cover			
Left rotation		Right rotation						Left rotation		Right rotation	
	01		02	CIP01 - Parallel T.2 = 2.1 [Nm]	A	CFP01 - Milled shank T.2 = 9.2 [Nm]	B				A
	03		04	CF005 - Milled shank T.2 = 8.4 [Nm]	F	CO001 - Tapered T.2 = 21.9 [Nm]	E				D
	05		06								
	07		08								

Displacement	
TYPE	CODE
XOT/0.17	01
XOT/0.25	02
XOT/0.45	04
XOT/0.57	05
XOT/0.76	06
XOT/0.98	07
XOT/1.27	09
XOT/1.52	11
XOT/2.30	13

Standard bodies			
Displacement cm3/rev	Standard threads		
	0.17	B - B	Z - B
0.25	B - B	Z - B	Z - Z
0.45	B - B	Z - B	Z - Z
0.57	B - B	Z - B	Z - Z
0.76	B - B	Z - B	Z - Z
0.98	B - B	Z - B	Z - Z
1.27	B - B	Z - B	Z - Z
1.52	B - B	Z - B	Z - Z
2.30	B - B	Z - B	Z - Z

Table showing standard flange and thread combinations available in stock

Body (threads/flanges)													
	A		B		C		D		E		F		G
	H		I	Closed Body	Z								