

# intermediate pump - series XV

XO1-2

INTERMEDIATE PUMP TO BE COUPLED WITH XV2  
FEMALE Ø36,5 FLANGE

**X 0 I 06 42 A B B A**

Series	X	series XV
Group	0	group 0
Category	I	intermediate pump
Displacement	06	0.76
Flange	42	Ø36.5 female right rotation 2P+0P, 3P+0P
Shaft	A	CIP01 - Intermediate for 1+0 - 2+0 (Parallel ø7 - M7x1 - key thk. 2)
Body	IN	inlet - 1/4" GAS
	OUT	outlet - 1/4" GAS
Cover	A	ø22 female cover for left multiple pump element

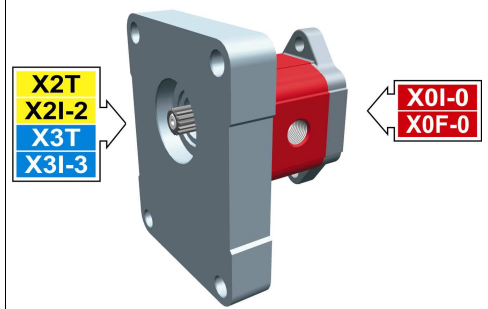

XI004

Technical data table

TYPE	Displacement cm3/rev	Max. Pressure		CODE	
		P1 bar	P3 bar	Left rotation	Right rotation
XO1-2/0.17	0,16	220	260	X 0 I 01 41 A B B A	X 0 I 01 42 A B B A
XO1-2/0.25	0,24	220	260	X 0 I 02 41 A B B A	X 0 I 02 42 A B B A
XO1-2/0.45	0,45	220	280	X 0 I 04 41 A B B A	X 0 I 04 42 A B B A
XO1-2/0.57	0,56	220	280	X 0 I 05 41 A B B A	X 0 I 05 42 A B B A
XO1-2/0.76	0,75	220	280	X 0 I 06 41 A B B A	X 0 I 06 42 A B B A
XO1-2/0.98	0,92	220	280	X 0 I 07 41 A B B A	X 0 I 07 42 A B B A
XO1-2/1.27	1,26	220	280	X 0 I 09 41 A B B A	X 0 I 09 42 A B B A
XO1-2/1.52	1,48	220	280	X 0 I 11 41 A B B A	X 0 I 11 42 A B B A
XO1-2/2.30	2,28	190	210	X 0 I 13 41 A B B A	X 0 I 13 42 A B B A

P1) Max. working pressure - P3) Max. peak pressure

For heavy-duty applications, it is recommended to check the admissible torque of the shaft

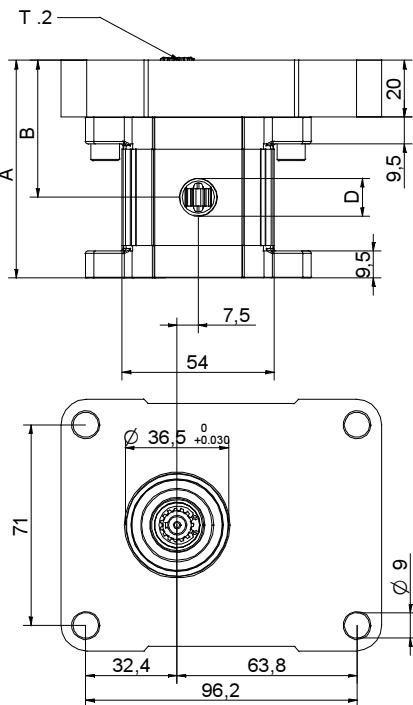
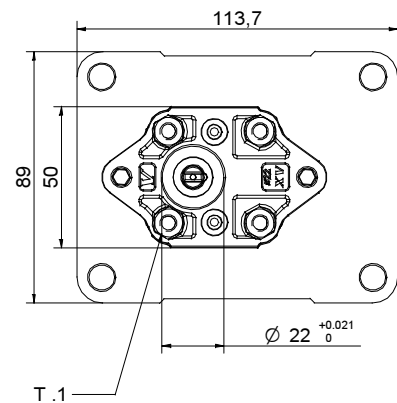

T.1 = 11.7÷13.7 [Nm] - screw tightening torque M6

T.2 = 2.1 [Nm] - admissible shaft torque (N.B. When choosing a shaft, always check the admissible torque).

# Table of variations

**XO1-2**

## Female $\varnothing 36.5$ FLANGE

Female $\varnothing 36.5$ FLANGE		Shaft		Cover		
Left rotation	Right rotation			Left rotation	Right rotation	
		CIP01 - Parallel $T.2 = 2.1$ [Nm] $m=0.75$ $Z=15$ 				A
41	42	A				D

Displacement	
TYPE	CODE
XO1-2/0.17	01
XO1-2/0.25	02
XO1-2/0.45	04
XO1-2/0.57	05
XO1-2/0.76	06
XO1-2/0.98	07
XO1-2/1.27	09
XO1-2/1.52	11
XO1-2/2.30	13

Standard bodies	
Displacement cm3/rev standard thread	
0.17	B - B
0.25	B - B
0.45	B - B
0.57	B - B
0.76	B - B
0.98	B - B
1.27	B - B
1.52	B - B
2.30	B - B

Table showing standard flange and thread combinations available in stock

Body (threads/flanges)													
	A		B		C		D		E		F		G
	H		I	Closed Body		Z							