

## ■ Proportional Electro-Hydraulic Flow Control (and Check) Valves

The system flow rate can be controlled remotely as desired by regulating input voltage. Further, since pressure and temperature compensation functions are provided, the preselected flow rate is not affected by pressure (load) or temperature (fluid viscosity).



### ■ Specifications

Model Numbers		EHF*G-03- 60 125	EHF*G-06-250
Description			
Max. Operating Pres. MPa (PSI)		20.6 (3000)	24.5 (3550)
Max. Metred Flow L/min (U.S.GPM)		60: 60 (15.8) 125: 125 (33)	250 (66)
Min. Metred Flow L/min (U.S.GPM)		1 (.26)	2.5 (.66)
Min. Differential Pressure *1 MPa (PSI)		1.0 (145)	1.0 (145)
Free Flow L/min (U.S.GPM) (Only with Check Valve)		130 (34.3)	280 (73.9)
Pilot Flow L/min (U.S.GPM)	at Normal	0.5 (.13)	1 (.26)
	at Transition	2.6 (.69)	4 (1.06)
Min. Pilot Pressure MPa (PSI)		1.0 (145)	1.5 (215)
Frequency Response		12 Hz (-90 degree)	
Hysteresis		3% or less	
Repeatability		1% *2 or less	
Coil Resistance		10 Ω	
Supply Electric Power		24 V DC (21 to 28 V DC Included Ripple)	
Power Input (Max.)		28 W	
Input signal		Max. Metred Flow / 5V DC	
Input Impedance		10 kΩ	
Ambient Temperature		0 - 50°C (32 - 122°F) (With Circulated Air)	

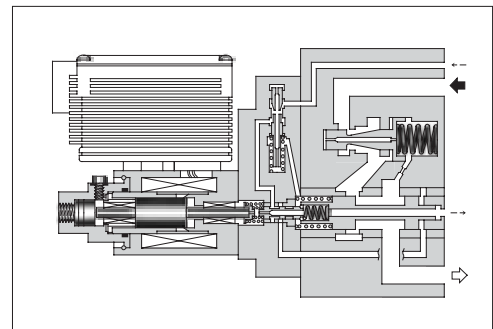

### Graphic Symbols

#### ● EHF

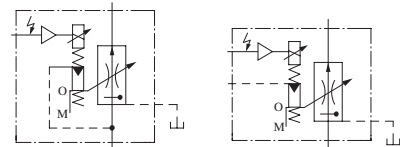

Internal Pilot

External Pilot

#### ● EHF

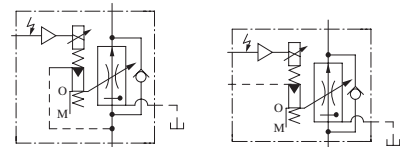

Internal Pilot

External Pilot

- ★1. Minimum differential pressure means fine pressure compensation at inlet and outlet port.
- ★2. The repeatability of the valve is obtained by having it tested independently on the conditions similar to its original testing.

### ■ Model Number Designation

F-	EHF	G	-03	-60	-E	-50
Special Seals	Series Number	Type of Mounting	Valve Size	Max. Metred Flow L/min (U.S.GPM)	Pilot Connection	Design Number
<b>F:</b> Special Seals for Phosphate Ester Type Fluid (Omit if not required)	<b>EHF:</b> Proportional Electro-Hydraulic Flow Control Valve  <b>EHFC:</b> Proportional Electro-Hydraulic Flow Control and Check Valve	<b>G:</b> Sub-plate Mounting	<b>03</b>	<b>60:</b> 60 (15.8) <b>125:</b> 125 (33)	<b>None:</b> Internal Pilot  <b>E:</b> External Pilot	<b>50</b>
			<b>06</b>	<b>250:</b> 250 (66)		<b>50</b>